

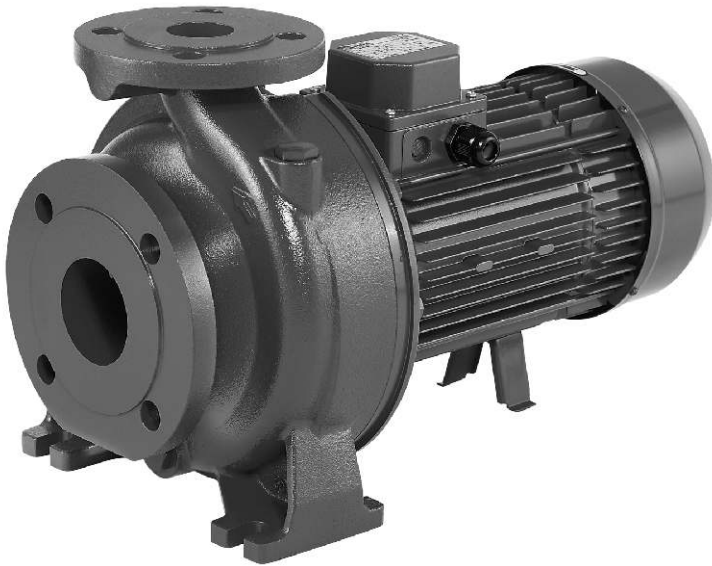

**To EN 733
(ex DIN 24255)**



A very economical range of high quality pumps made in Europe utilising cast iron casings and extended shaft motors.

The use of IE3 motors (3 phase versions) and the smooth surfaces of the stamped stainless steel impellers result in a product of consistent high quality and efficiency.

The back pull-out construction permits the disassembly and overhaul of the impeller, mechanical seal and motor without removal of the suction or discharge piping, or pump casing.

With dimensions to EN733 (ex. DIN24255) upgrading existing installations can be easy.

**Robust cast iron casing with
304 stainless steel impeller & back cover**



**Economical extended
motor shaft design.**

Specifications

- End suction centrifugal pump with closed impeller
- Maximum working pressure: 10 bar
- Liquid temperature: -5 °C to +90 °C (standard construction)

Materials

- Pump casing: Cast Iron
- Impeller: 304 Stainless Steel
- Casing cover: 304 Stainless Steel
- Shaft: 304 Stainless Steel (wetted part)
- Motor bracket: Cast Iron
- Mechanical seal: Carbon/Ceramic/NBR

Motor Data

- Extended shaft motors, aluminium frame
- 2 pole (2900rpm)
- TEFC, 50 Hz
- Insulation class F
- IP55 Protection

Three phase motors

- IE3 high efficiency motors
- 1.1 to 11 kW
- Dual voltage 230/400V ±10% (up to 4.0 kW)
400/690V ±10% (5.5 kW & above)

Single phase motors

- 1.1 to 2.2 kW only
- 230 V (±10%)

Options

- High temperature seal (110 °C)
(Carbon/Ceramic/Viton seal, Viton O' Rings)
- Hard faced seal (110 °C)
(SiC/SiC/Viton seal, Viton O' Rings)

Accessories

- Zinc plated carbon steel companion flange kits available

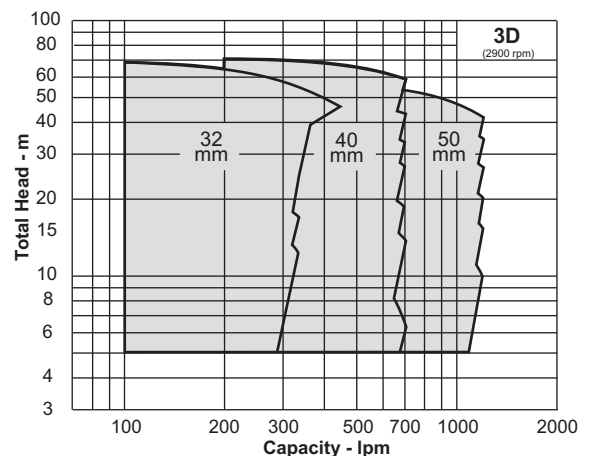

Model Code

3D 40 - 125 / 2.2 (-M)

- 3D = 2 pole model
- 40 = Discharge Size Ø mm
- 125 = Nominal Impeller Diameter mm
- 2.2 = Motor Size kW
- (-M) = Single phase models only

- 32 mm to 50 mm discharge size
- 1.1 to 11 kW motor power
- Flows to 1200 lpm
- Heads to 70 m

Performance Curves & Chart

Model **3D**

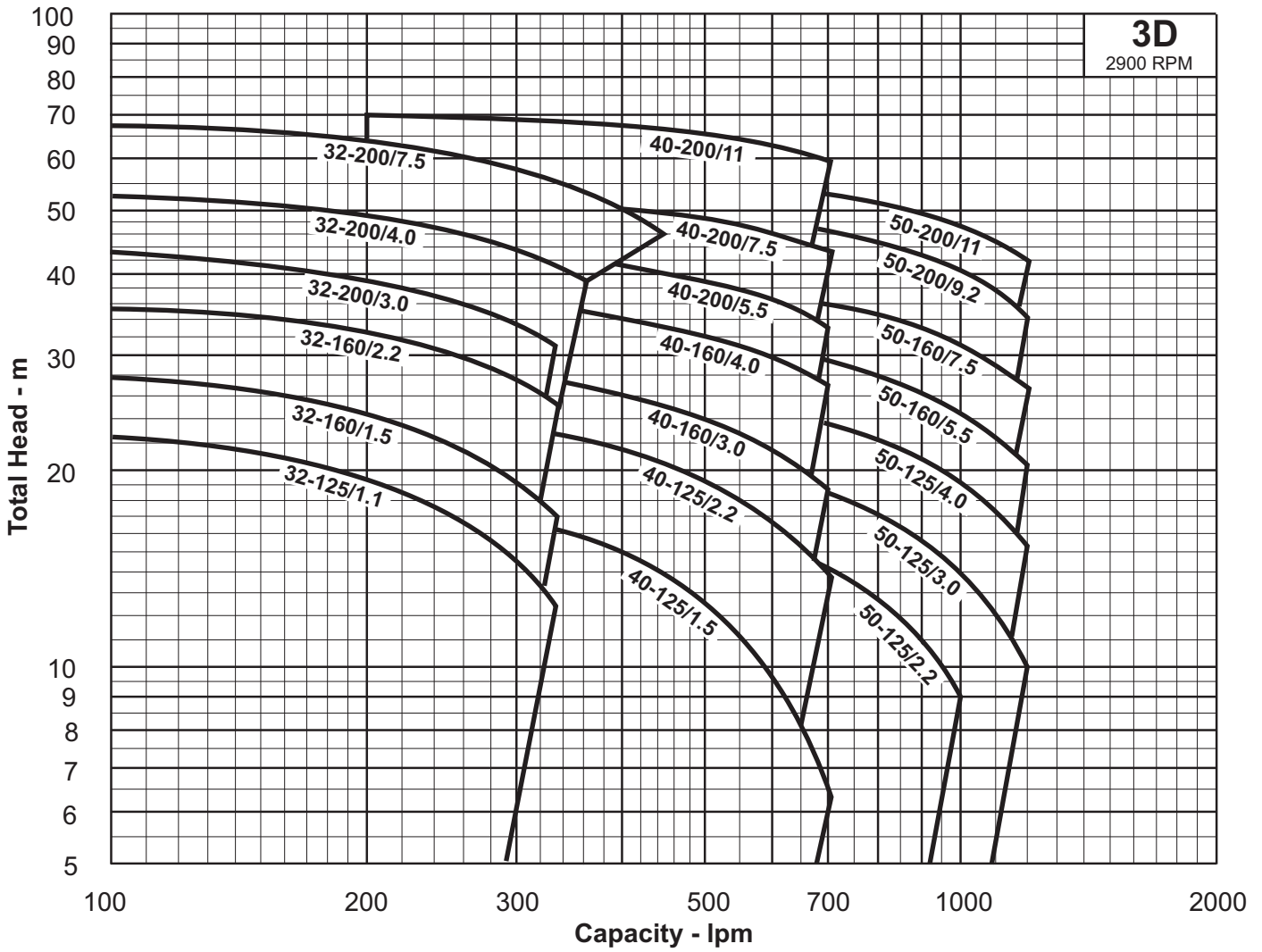

Pump Model	Motor Output	Discharge/Suction Ø mm	Full Load 1 Phase 230 V	Current 3 Phase 400 V	Capacitor (1 Phase models only)	Capacity - lpm									
						0	100	150	200	250	300	333	360	400	450
3D 32-125/1.1 (M)	1.1 kW	32 / 50 mm	6.7 A	3.3 A	31.5 µF	23	22.4	21.2	19.3	17.1	14.4	12.5	-	-	-
3D 32-160/1.5 (M)	1.5 kW	32 / 50 mm	9.6 A	3.3 A	40 µF	28.5	27.5	25.9	23.7	21.3	18.5	16.4	-	-	-
3D 32-160/2.2 (M)	2.2 kW	32 / 50 mm	13.3 A	4.7 A	50 µF	36.7	35.4	34.1	32.2	29.8	27.3	25.5	-	-	-
3D 32-200/3.0	3.0 kW	32 / 50 mm	—	6.4 A	—	44	43	41	39	36.5	33	31	-	-	-
3D 32-200/4.0	4.0 kW	32 / 50 mm	—	8.7 A	—	53	52.5	51	49	46	43	41	39	-	-
3D 32-200/7.5	7.5 kW	32 / 50 mm	—	13.6 A	—	68	67	65	63	61	57	55	53	50	46

Pump Model	Motor Output	Discharge/Suction Ø mm	Full Load 1 Phase 230 V	Current 3 Phase 400 V	Capacitor (1 Phase models only)	Capacity - lpm									
						0	200	250	300	350	400	450	500	600	700
3D 40-125/1.5 (M)	1.5 kW	40 / 65 mm	9.6 A	3.3 A	40 µF	19	18.2	17.6	16.8	15.9	14.8	13.7	12.4	9.6	6.3
3D 40-125/2.2 (M)	2.2 kW	40 / 65 mm	13.3 A	4.7 A	50 µF	25	24.4	23.9	23.2	22.4	21.4	20.4	19.2	16.5	13.7
3D 40-160/3.0	3.0 kW	40 / 65 mm	—	6.4 A	—	31	29.4	28.7	27.8	26.8	25.8	24.8	23.7	21.4	18.7
3D 40-160/4.0	4.0 kW	40 / 65 mm	—	8.7 A	—	38.8	37.2	36.5	35.7	34.8	33.8	32.8	31.8	29.5	27
3D 40-200/5.5	5.5 kW	40 / 65 mm	—	10.6 A	—	45.5	44.5	44	43	42	41	40	39	36.3	33
3D 40-200/7.5	7.5 kW	40 / 65 mm	—	13.6 A	—	55	53.5	53	52	51.5	50.5	49.5	48.5	46	43
3D 40-200/11.0	11.0 kW	40 / 65 mm	—	21.3 A	—	71	70	69	68.5	67.5	67	66	65	63	60

Pump Model	Motor Output	Discharge/Suction Ø mm	Full Load 1 Phase 230 V	Current 3 Phase 400 V	Capacitor (1 Phase models only)	Capacity - lpm									
						0	400	500	600	700	800	900	1000	1100	1200
3D 50-125/2.2 (M)	2.2 kW	50 / 65 mm	13.3 A	4.7 A	50 µF	19.5	18	17	15.7	14.2	12.6	10.9	9	-	-
3D 50-125/3.0	3.0 kW	50 / 65 mm	—	6.4 A	—	22.5	21.5	20.8	19.8	18.5	17.1	15.5	13.8	12	10
3D 50-125/4.0	4.0 kW	50 / 65 mm	—	8.7 A	—	26.5	25.8	25.3	24.5	23.5	22.2	20.7	19	17.2	15.3
3D 50-160/5.5	5.5 kW	50 / 65 mm	—	10.6 A	—	33	32	31.5	30.5	29.3	27.9	26.2	24.4	22.4	20
3D 50-160/7.5	7.5 kW	50 / 65 mm	—	13.6 A	—	39.5	38.2	37.6	36.9	35.8	34.5	32.9	30.9	28.9	26.7
3D 50-200/9.2	9.2 kW	50 / 65 mm	—	17.2 A	—	51.5	-	49.5	48	46.5	44.5	42.5	40	37.6	34.4
3D 50-200/11.0	11.0 kW	50 / 65 mm	—	21.3 A	—	57.5	-	55.5	54.5	52.5	51	49	47	44.5	42

Dimensions

Model 3D

Units: mm unless otherwise specified

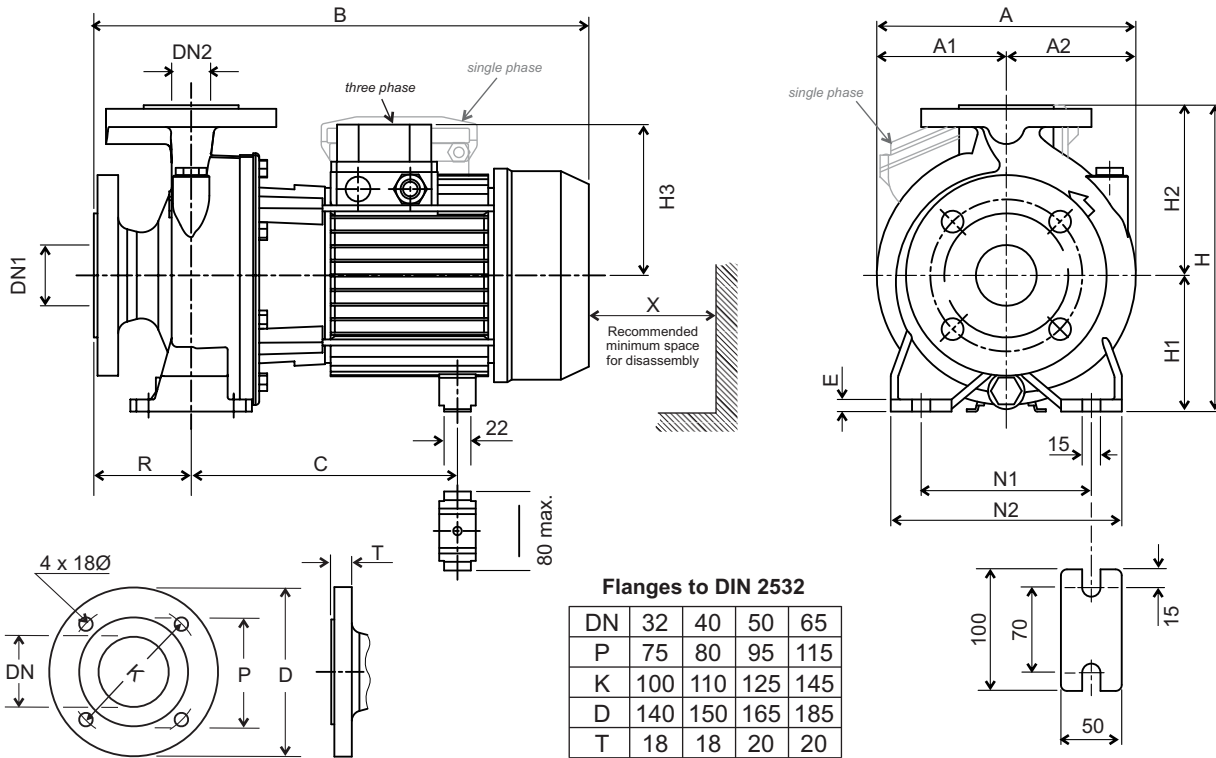

DN2 x DN1	Pump Models	Dimensions														Weight	
		A	A1	A2	1- B 3-	1- C 3-	R	H	H1	H2	1- H3 3-	N1	N2	X	1- (kg) 3-		
32 mm x 50 mm	3D 32-125/1.1 (M)	212	106	106	408 / 431	230 / 232	80	252	112	140	141 / 119	140	190	110	25 / 30		
	3D 32-160/1.5 (M)	254	127	127	408 / 431	230 / 232	80	292	132	160	141 / 119	190	240	110	29 / 34		
	3D 32-160/2.2 (M)	254	127	127	408 / 431	230 / 232	80	292	132	160	141 / 119	190	240	110	36 / 36		
	3D 32-200/3.0	296	148	148	- / 471	- / 244	80	340	160	180	- / 124	190	240	110	- / 48		
	3D 32-200/4.0	296	148	148	- / 494	- / 253	80	340	160	180	- / 141	190	240	110	- / 50		
	3D 32-200/7.5	296	148	148	- / 539	- / 275	80	340	160	180	- / 150	190	240	110	- / 65		
40 mm x 65 mm	3D 40-125/1.5 (M)	220	108	112	408 / 431	230 / 232	80	252	112	140	141 / 119	160	210	115	26 / 30		
	3D 40-125/2.2 (M)	220	108	112	408 / 431	230 / 232	80	252	112	140	141 / 119	160	210	115	32 / 32		
	3D 40-160/3.0	254	127	127	- / 471	- / 244	80	292	132	160	- / 124	190	240	115	- / 39		
	3D 40-160/4.0	254	127	127	- / 494	- / 253	80	292	132	160	- / 141	190	240	115	- / 48		
	3D 40-200/5.5	296	148	148	- / 539	- / 275	100	340	160	180	- / 150	212	265	115	- / 60		
	3D 40-200/7.5	296	148	148	- / 559	- / 275	100	340	160	180	- / 150	212	265	115	- / 66		
50 mm x 65 mm	3D 50-125/2.2 (M)	254	127	127	428 / 451	230 / 232	100	292	132	160	141 / 119	190	240	125	35 / 37		
	3D 50-125/3.0	254	127	127	- / 491	- / 244	100	292	132	160	- / 124	190	240	125	- / 40		
	3D 50-125/4.0	254	127	127	- / 514	- / 253	100	292	132	160	- / 141	190	240	125	- / 48		
	3D 50-160/5.5	296	148	148	- / 539	- / 275	100	340	160	180	- / 150	212	265	125	- / 60		
	3D 50-160/7.5	296	148	148	- / 559	- / 275	100	340	160	180	- / 150	212	265	125	- / 67		
	3D 50-200/9.2	296	148	148	- / 595	- / 359	100	360	160	200	- / 178	212	265	125	- / 77		
	3D 50-200/11.0	296	148	148	- / 595	- / 359	100	360	160	200	- / 178	212	265	125	- / 83		

Specifications subject to change without notice

Companion flange sets (available separately as an accessory)

A set consists of :-

- 2 of zinc plated carbon steel flanges
- 2 of EPDM gaskets
- 8 of zinc plated bolts with washers & nuts (M16 x 55)

Suit models	Suction Side						Discharge Side						Approx. Weight kg
	DN	Gas Thread	KF	DF	T1	T2	DN	Gas Thread	KF	DF	T1	T2	
32 mm models	50	2"	125	165	15	19	32	1 1/4"	100	140	11.5	15	3.5
40 mm models	65	2 1/2"	145	185	14	23	40	1 1/2"	110	150	11.5	17.5	4
50 mm models	65	2 1/2"	145	185	14	23	50	2"	125	165	15	19	4

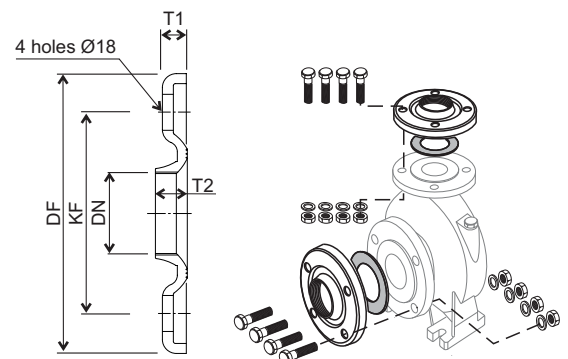

Typical construction

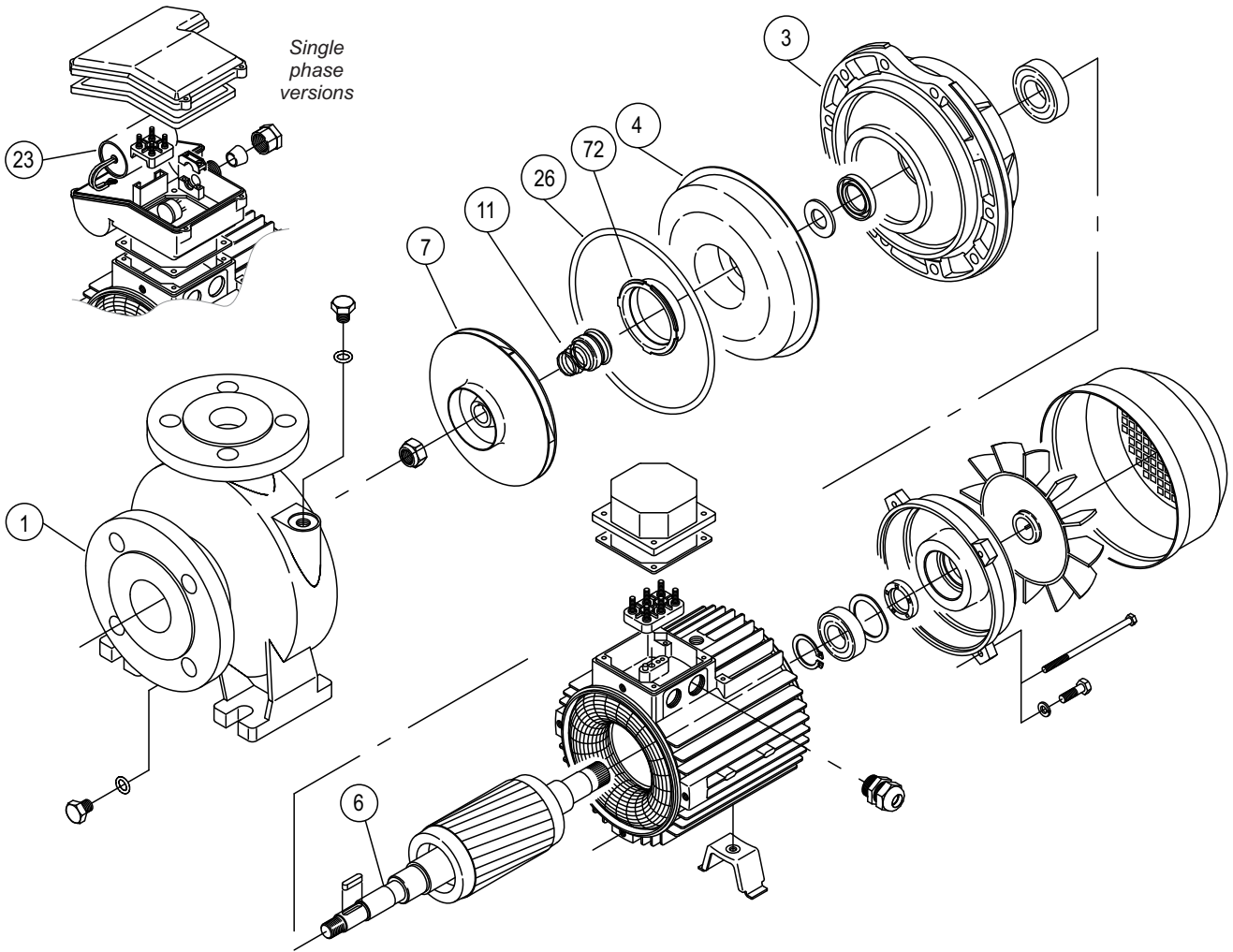

Item	Description	Suits models	Materials
1	Casing	All models	Cast Iron
3	Motor bracket	All models	Cast Iron
4	Casing cover	All models	304 Stainless Steel - stamped
6	Shaft (& rotor)	All models <small>(Material refers to part in contact with liquid)</small>	304 Stainless Steel
7	Impeller	All models	304 Stainless Steel - stamped
11	Mechanical seal	All models	Carbon/Ceramic/NBR <small>Carbon/Ceramic/Viton - High Temp. Option SiC/SiC/Viton - Hard Face Option</small>
23	Capacitor	Single phase models only	—
26	O-Ring (casing)	All models	NBR <small>Viton - when optional seals fitted</small>
72	Casing ring (rear)	32-200, 40-200, 50-125, 160, 200	304 Stainless Steel - stamped

Casing



Cast Iron

Impeller



Stamped 304
Stainless Steel

Casing
Cover



Stamped 304
Stainless Steel

Specifications subject to change without notice