



# Stainless Steel Pumps

# Model 3LS4 316 S/S Centrifugal Pumps (4 pole)

To DIN 24255



**Stub shaft design**  
**Uses IEC standard motors**



**Standard with high quality Silicon Carbide mechanical seal**

**All the hydraulic and wetted components are manufactured in 316 Stainless Steel**

This series of stainless steel pumps feature a unique one piece volute casing that is produced using an advanced computer controlled Plasma stamping system that ensures total quality control during manufacture. With the smooth surfaces of stamped stainless steel, this results in consistent high standard products, of superior quality and high efficiency. (Cast casing on 65-250 & 80 models)

The back pull-out construction permits the disassembly and overhaul of the impeller, mechanical seal and motor without removal of the suction or discharge piping, or pump casing.

The centre line discharge and foot support under the casing ensure maximum resistance to misalignment and distortion from pipe loads.

**Available as pump end kit (without motor)**

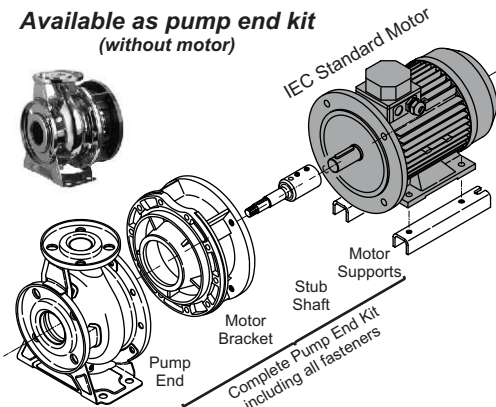

**Standard IEC motors used, allowing for special enclosure or specific brand motors to be fitted.**

### Specifications

- End suction centrifugal pump with closed impeller
- Maximum working pressure: 10 bar
- Liquid temperature: -10 °C to +110 °C

### Materials

- Pump casing: 316 Stainless Steel
- Impeller: 316 Stainless Steel
- Casing cover: 316 Stainless Steel
- Shaft: 316 Stainless Steel (wetted part)
- Motor bracket: Cast Iron
- Mechanical seal: SiC/SiC/Viton

### Motor Data

- IEC standard 4 pole 50 Hz motors
- Normally fitted with WEG motors
- 3 Phase, TEFC, IP55 or above, Class F or above

### Range

- 32 to 80 mm Ø discharge
- 0.25 to 7.5 kW - 3 Phase

### Supply

- Available complete with motor or as a pump end kit without motor

### Options

- Other motor brands, types, etc. on request

### Accessories

- Companion flange kits.



**Precision cast casing on 65-250 & 80 models**

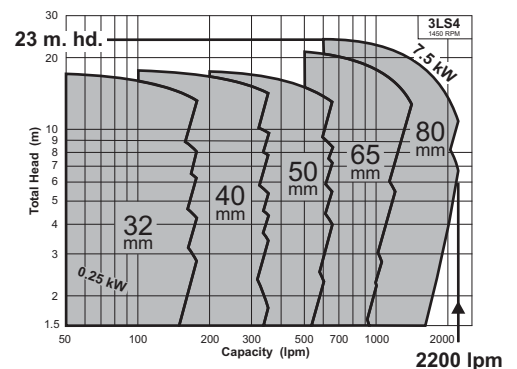

- Over 35 model sizes
- 32 mm to 80 mm discharge
- 0.25 to 7.5 kW motor power
- Flows to 2200 lpm
- Heads to 23 metres

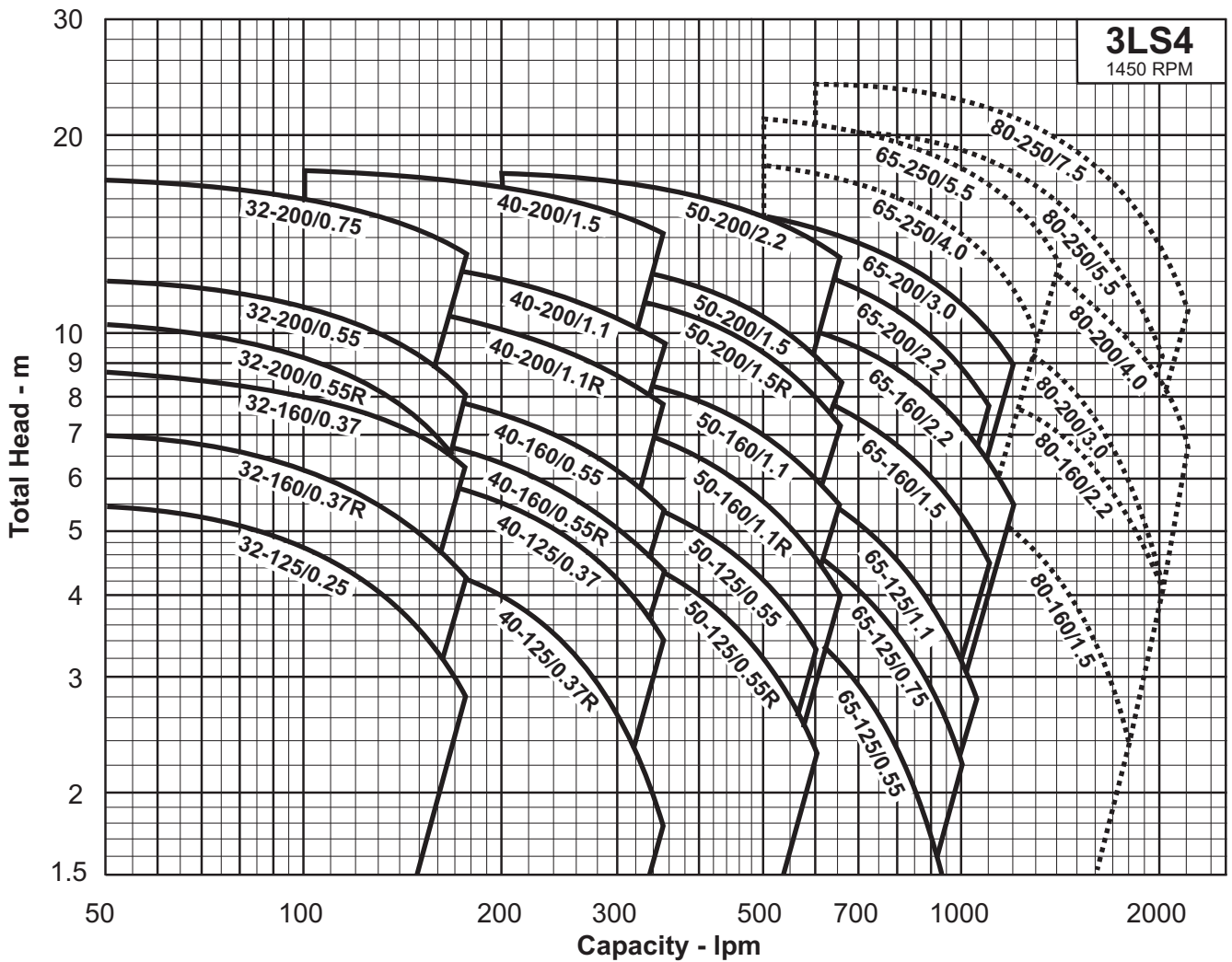

**Model Code**

3LS4 50 - 160 / 1.5 R

- Reduced Diameter Impeller
- Motor Size kW
- Nominal Impeller Diameter mm
- Discharge Size Ø mm
- 4 = 4 Pole speed
- Model; 3LS with motor; 3LSF without motor (kit)

..... These models available on request

Synchronous Speed: 1500 rpm

Water temp: 20 °C

Applicable standard of test: ISO 2458 Class C

## Configuration

3LS4 pumps use IEC standard motors. 3 phase WEG cast iron motors are generally fitted as standard, but specific brands, special enclosures, etc. can also be supplied. The requirements for frame size and mounting are in the dimension table. Note that B5 = Flange mount; B35 = Foot & Flange mount.

The style of motor support varies depending on model and motor size, as shown in the figures below and referred to in the dimension table.

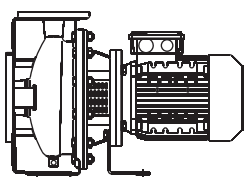

Fig 1

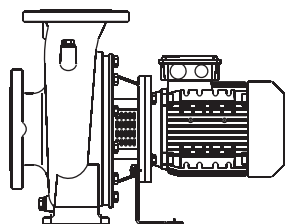

Fig 1A

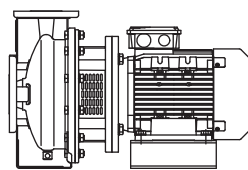

Fig 2

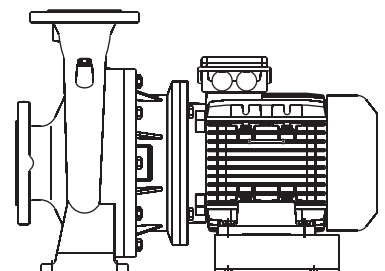
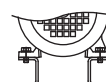
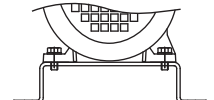

Fig 3



# Dimensions - with cast iron W22 WEG motors

Model **3LS4**

Units: mm unless otherwise specified

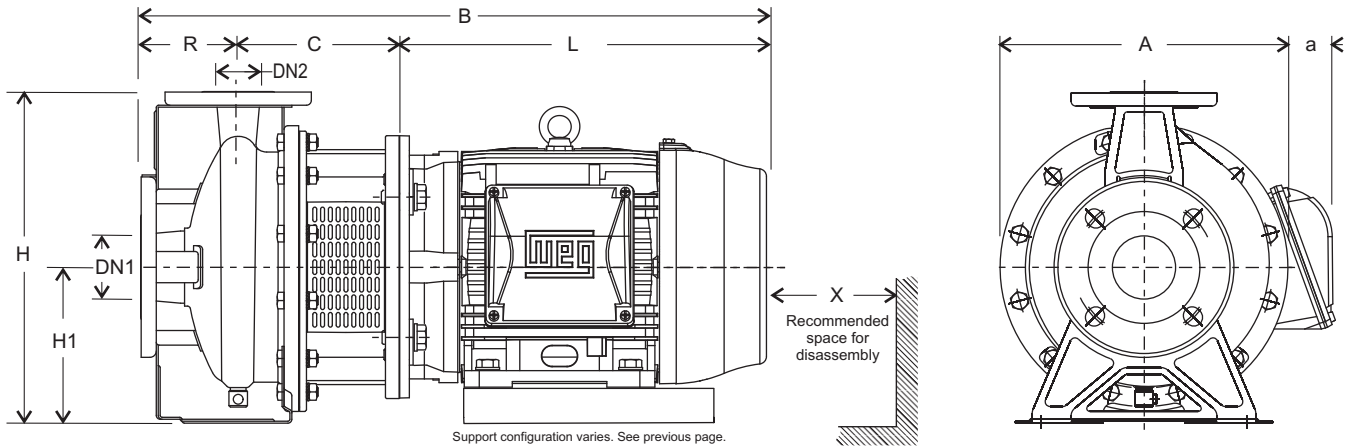

Support configuration varies. See previous page.

Dimensions & weights refer to units fitted with high efficiency 3 Phase cast iron WEG W22 motors

\* FLC = Motor full load current (A) @ 400 V

DN2 x DN1	Pump Model (...../kW)	Motor details				Dimensions (mm)										Weight (kg)		
		FLC*	Frame	Mount	Config.	H1	H	R	C	L	B	A	a	X	Pump End	Motor	Total	
32 mm x 50 mm	3LS4 32-125/0.25	0.969	71	B5	Fig 1	112	252	80	108	218	406	213	24	110	15	10	25	
	3LS4 32-160/0.37R	0.969	71	B5	Fig 1	132	292	80	108	218	406	254	3	110	20	10	30	
	3LS4 32-160/0.37	0.969	71	B5	Fig 1	132	292	80	108	218	406	254	3	110	20	10	30	
	3LS4 32-200/0.55R	1.24	80	B5	Fig 1	160	340	80	118	236	434	296	9	110	24	13	37	
	3LS4 32-200/0.55	1.24	80	B5	Fig 1	160	340	80	118	236	434	296	9	110	24	13	37	
	3LS4 32-200/0.75	1.59	80	B5	Fig 1	160	340	80	118	236	434	296	9	110	24	16	40	
40 mm x 65 mm	3LS4 40-125/0.37R	0.969	71	B5	Fig 1	112	252	80	108	218	406	213	24	115	17	10	27	
	3LS4 40-125/0.37	0.969	71	B5	Fig 1	112	252	80	108	218	406	213	24	115	17	10	27	
	3LS4 40-160/0.55R	1.24	80	B5	Fig 1	132	292	80	118	236	434	254	3	115	20	13	33	
	3LS4 40-160/0.55	1.24	80	B5	Fig 1	132	292	80	118	236	434	254	3	115	20	13	33	
	3LS4 40-200/1.1R	2.31	90S	B5	Fig 1	160	340	100	130	254	484	296	9	115	27	23	50	
	3LS4 40-200/1.1	2.31	90S	B5	Fig 1	160	340	100	130	254	484	296	9	115	27	23	50	
50 mm x 65 mm	3LS4 40-200/1.5	3.19	90L	B5	Fig 1	160	340	100	130	279	509	296	9	115	27	24	51	
	3LS4 50-125/0.55R	1.24	80	B5	Fig 1	132	292	100	118	236	434	254	12	125	21	13	34	
	3LS4 50-125/0.55	1.24	80	B5	Fig 1	132	292	100	118	236	434	254	12	125	21	13	34	
	3LS4 50-160/1.1R	2.31	90S	B5	Fig 1	160	340	100	130	254	484	296	9	125	26	23	49	
	3LS4 50-160/1.1	2.31	90S	B5	Fig 1	160	340	100	130	254	484	296	9	125	26	23	49	
	3LS4 50-200/1.5R	3.19	90L	B5	Fig 1	160	360	100	130	279	519	296	9	125	30	24	54	
65 mm x 80 mm	3LS4 50-200/1.5	3.19	90L	B5	Fig 1	160	360	100	130	279	519	296	9	125	30	24	54	
	3LS4 50-200/2.2	4.49	100L	B35	Fig 2	160	360	100	130	316	546	296	19	125	30	35	65	
	3LS4 65-125/0.55	1.24	80	B5	Fig 1	160	340	100	118	236	454	254	12	145	26	13	39	
	3LS4 65-125/0.75	1.59	80	B5	Fig 1	160	340	100	118	236	454	254	12	145	28	16	44	
	3LS4 65-125/1.1	2.31	90S	B5	Fig 1	160	340	100	130	254	484	254	30	145	29	23	52	
	3LS4 65-160/1.5	3.19	90L	B5	Fig 1	160	360	100	130	279	509	296	19	145	30	24	54	
	3LS4 65-160/2.2	4.49	100L	B35	Fig 2	160	360	100	142	316	558	296	19	145	30	35	65	
	3LS4 65-200/2.2	4.49	100L	B35	Fig 2	180	405	100	142	316	558	296	19	145	30	35	65	
80 mm x 100 mm	3LS4 65-200/3.0	6.07	100L	B35	Fig 2	180	405	100	142	316	558	296	19	145	30	38	68	
	3LS4 65-250/4.0	7.91	112M	B35	Fig 2	200	450	100	152	333	585	357	14	150	57	44	101	
	3LS4 65-250/5.5	10.3	132S	B35	Fig 3	200	450	100	152	372	624	357	40	150	57	69	126	
	3LS4 80-160/1.5	3.19	90L	B5	Fig 1A	180	405	125	130	279	534	320	5	150	51	24	75	
	3LS4 80-160/2.2	4.49	100L	B35	Fig 3	180	405	125	142	316	583	320	7	150	51	35	86	
	3LS4 80-200/3.0	6.07	100L	B35	Fig 3	180	430	125	152	316	593	357	-	150	59	38	97	

Specifications subject to change without notice

**Flanges to DIN 2532**

32, 40, 50 & 65 Ø mm

80 & 100 Ø mm

DN	32	40	50	65	80	100
P	75	80	95	115	120	135
K	100	110	125	145	160	180
D	140	150	165	185	200	225

- A** Typical with stamped casing  
(i.e. all 32, 40 & 50 mm & 65-125/160/200)
- B** Typical with cast casing  
(i.e. 65-250, & all 80)

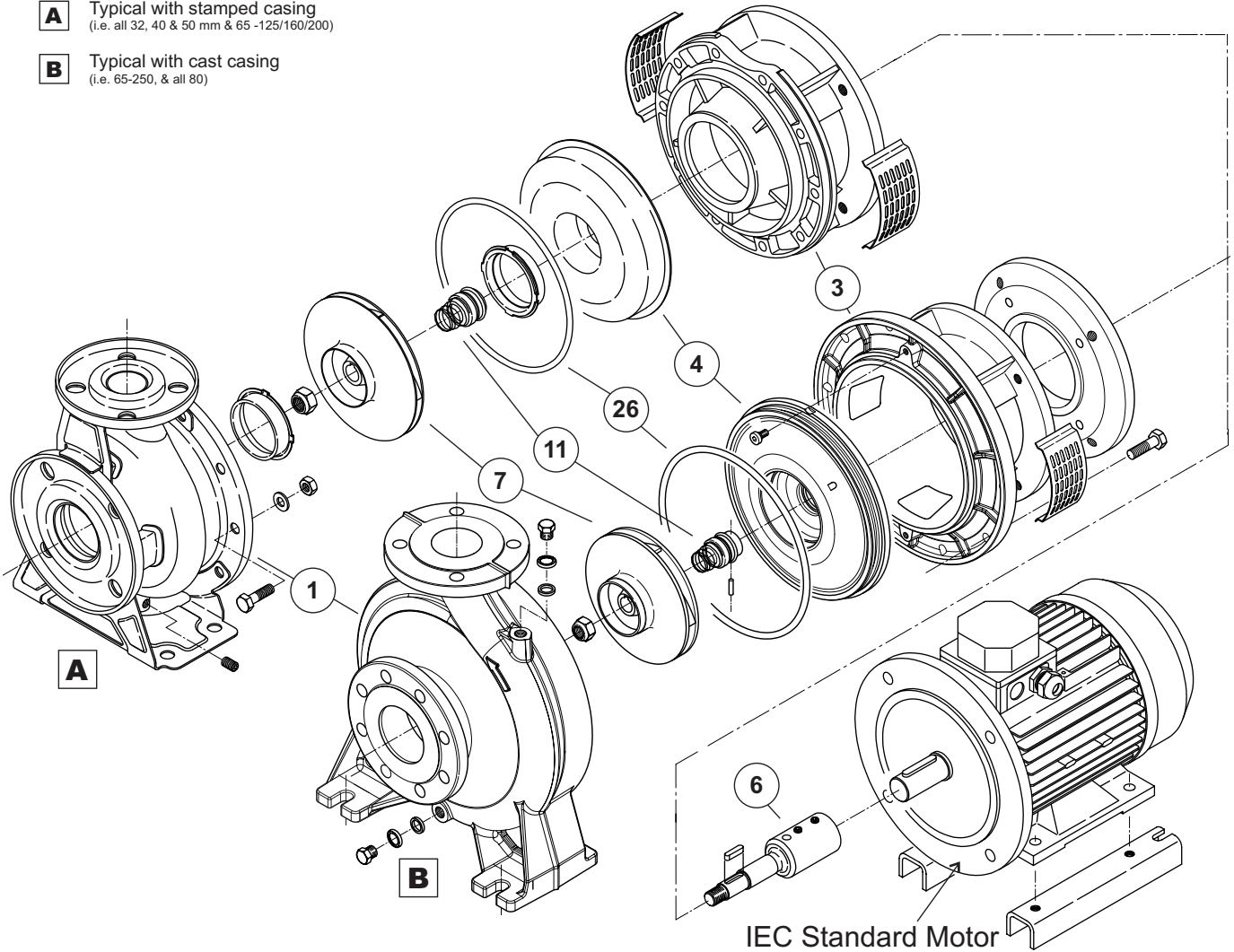

Note: Mounting and support feet varies between models.

Item	Description	Suits models	Materials
1	Casing	All 32, 40 & 50; 65-125/160/200	316L Stainless Steel - <i>stamped</i>
		65-250; All 80	316 Stainless Steel - <i>precision cast</i>
7	Impeller	All 32, 40 & 50	316L Stainless Steel - <i>stamped</i>
		All 65 & 80	316 Stainless Steel - <i>precision cast</i>
4	Casing cover	32, 40 & 50; 65-125/160/200; 80-160	316L Stainless Steel - <i>stamped</i>
		65-250; 80-200/250	316 Stainless Steel - <i>precision cast</i>
26	O-Ring (casing)	All models	Viton
11	Mechanical seal	All models	SiC/SiC/Viton with anti rotation device for stationary seat.
6	Stub shaft	All models	(Material refers to part in contact with liquid) 316 Stainless Steel
3	Motor bracket	All models	Cast Iron

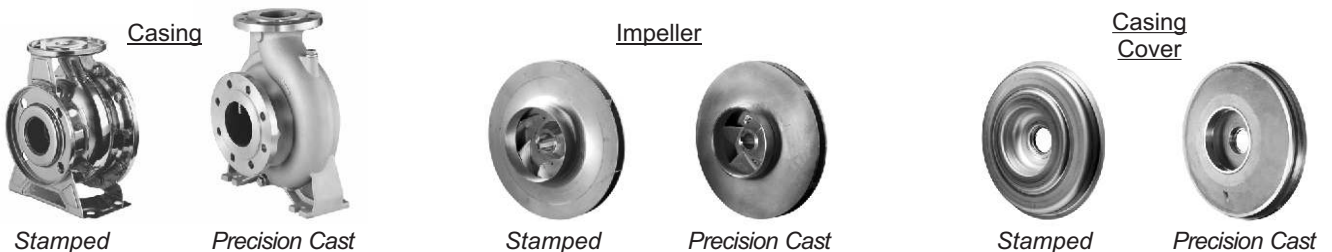

Specifications subject to change without notice