

WORLD'S ONLY FLEXIBLE STRAINER

SAFER TO USE, TO KEEP YOUR PUMPS RUNNING
LONGER, SAVING YOU TIME AND MONEY

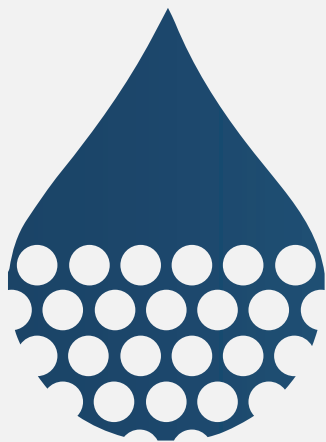

reflex

SUCTION STRAINER

world's only flexible suction strainer

REFLEX SUCTION STRAINER

ADVANCED FLEXIBLE DEWATERING AND FILTRATION DEVICES FOR HARSH ENVIRONMENTS

*Patent Pending no. 2015902356 -
Australian Design Registration Number
362894 - United States of America
Design Application Number 29/549,353
- International (PCT) Patent Application
Number PCT/AU2016/050160*

Born out of the high demands of the Australian underground mining environment, the Reflex Suction Strainer is designed to survive in hostile and high traffic environments. Moulded from an advanced blend of polymer rubbers, the Reflex Suction Strainer can handle extreme conditions including being run over by vehicles and machinery. The Reflex Suction Strainer costs less than conventional strainers, saving time in cleaning and replacements. Reflex Suction Strainers are safe to use and manufactured in accordance to ISO:9001 .

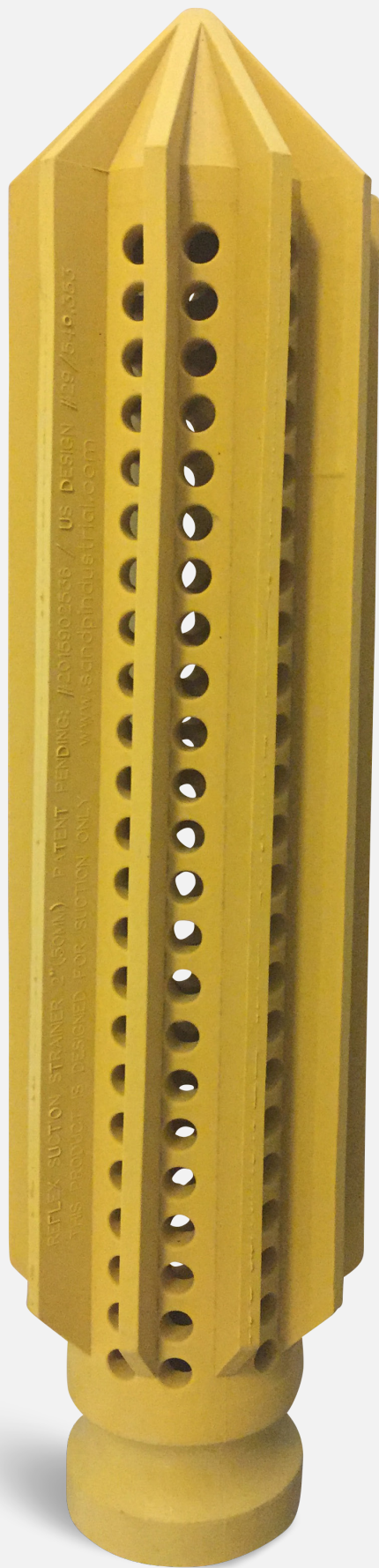

The S&P Reflex Suction Strainer is made from advanced, chemically engineered elastomeric polymers, allowing the design to operate in extremely harsh commercial environments or in domestic environments that require efficient water movement.

SAFETY

- ◆ The product uses vulcanised polymers eliminating sharp edges and reducing hand injuries (no metal) inherent in normal metal strainers
- ◆ Removal of submersible steel objects and sharp objects, reducing trip and cut hazards
- ◆ Lightweight and flexible design, meaning less impact on personnel and machinery when in contact
- ◆ Quick and easy to clean, so personnel will spend less time in heavy traffic areas repairing or replacing equipment

COST SAVINGS

- ◆ Does not corrode, therefore reduced replacement required
- ◆ Sustains many heavy contacts without breaking allowing the part to last longer
- ◆ Longer-lasting parts protect the pumps for longer periods, leading to less downtime, personnel intervention and repair and maintenance
- ◆ No need to drill costly bore holes and associated equipment in development roadways as the product can be used directly on roads and in direct contact with machinery
- ◆ More cost-effective pumps can be used keeping operating and capital costs down (diaphragm v submersible)

REFLEX SUCTION STRAINER SPECIFICATIONS

- ◆ **Flow rate** = 850 litres per minute
- ◆ **Hole Size** = 8mm
- ◆ **Filtration flow** = 12 times surface area to suction aperture
- ◆ **Elongation** = Safe capability 450%
- ◆ **Length** = 370mm or 470mm with hose tail
- ◆ **Total Width** = 90mm
- ◆ **Weight** = approx. 550g with hose tail 700g
- ◆ **Hardness** = 60 - 70 shore A
- ◆ **Temperature range** = Safe -66c to 100+c
- ◆ **Colours** = Black or Yellow

Vulcanised elastomeric compound
 - Manufactured in accordance to ISO9001 - Supports in excess of 100 tonnes of downward pressure - Fast attachment & detachment to Camlock fitting - No hose clamp required for hose tail fitting

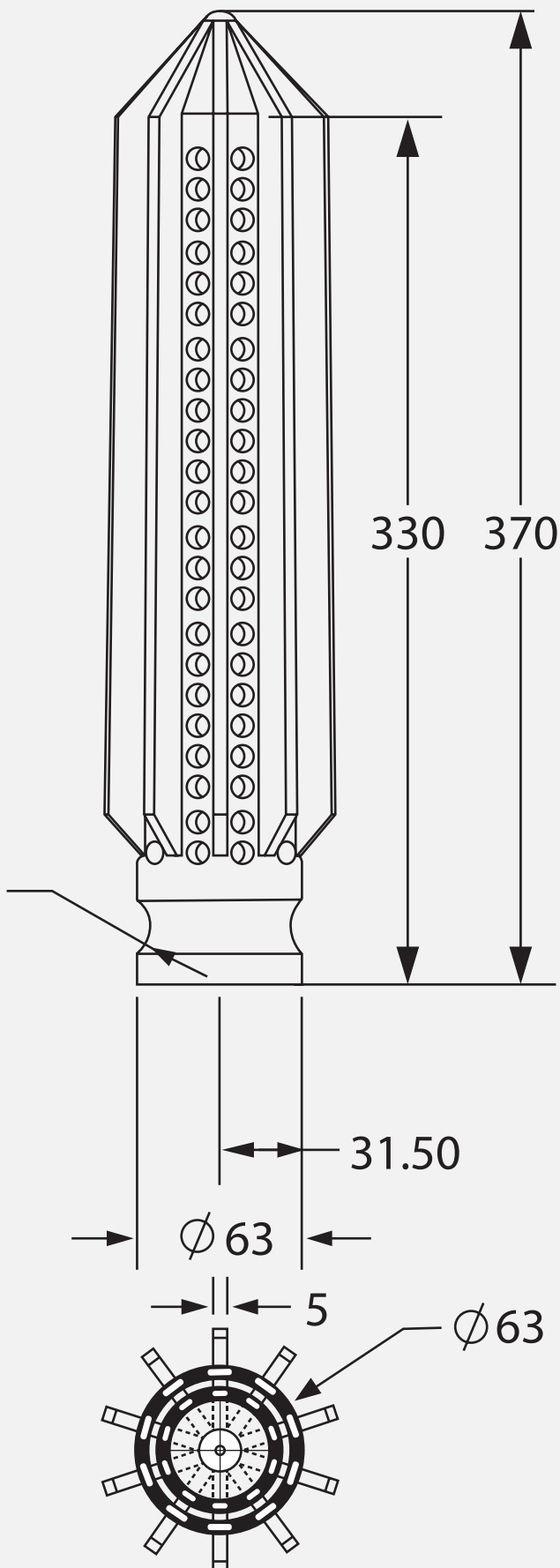

REFLEX SUCTION HOSE TAIL ATTACHMENT

ADVANCED DEWATERING DEVICE

The Reflex Suction Hose Tail attachment is designed to work with the Reflex Suction Strainer in harsh, heavy duty, high traffic environments to provide the complete solution to reduced pumping downtime, safer environments and reliable contaminant reduced fluid transfer. The flexible attachment allows for fast and simple connection for the Reflex Suction Strainer to any 2 inch hose, removing the need for metal or plastic connections in suction lines.

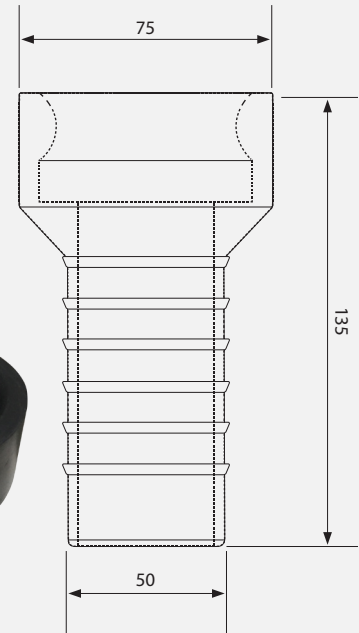

REFLEX SUCTION HOSE TAIL ATTACHMENT SPECIFICATIONS

- ◆ **Flow rate** = 850 litres per minute
- ◆ **Elongation** = Safe capability 450%
- ◆ **Length** = 135mm
- ◆ **Width** = 75mm
- ◆ **Weight** = approx. 150g
- ◆ **Hardness** = 90 shore A
- ◆ **Temperature range** = Safe -66c to 100+c
- ◆ **Size** = 2" (51mm) standard other sizes available on request.

Vulcanised elastomeric compound - Manufactured in accordance to ISO 9001 - Supports in excess of 100 tonnes of downward pressure



MINING & TUNNELLING APPLICATIONS

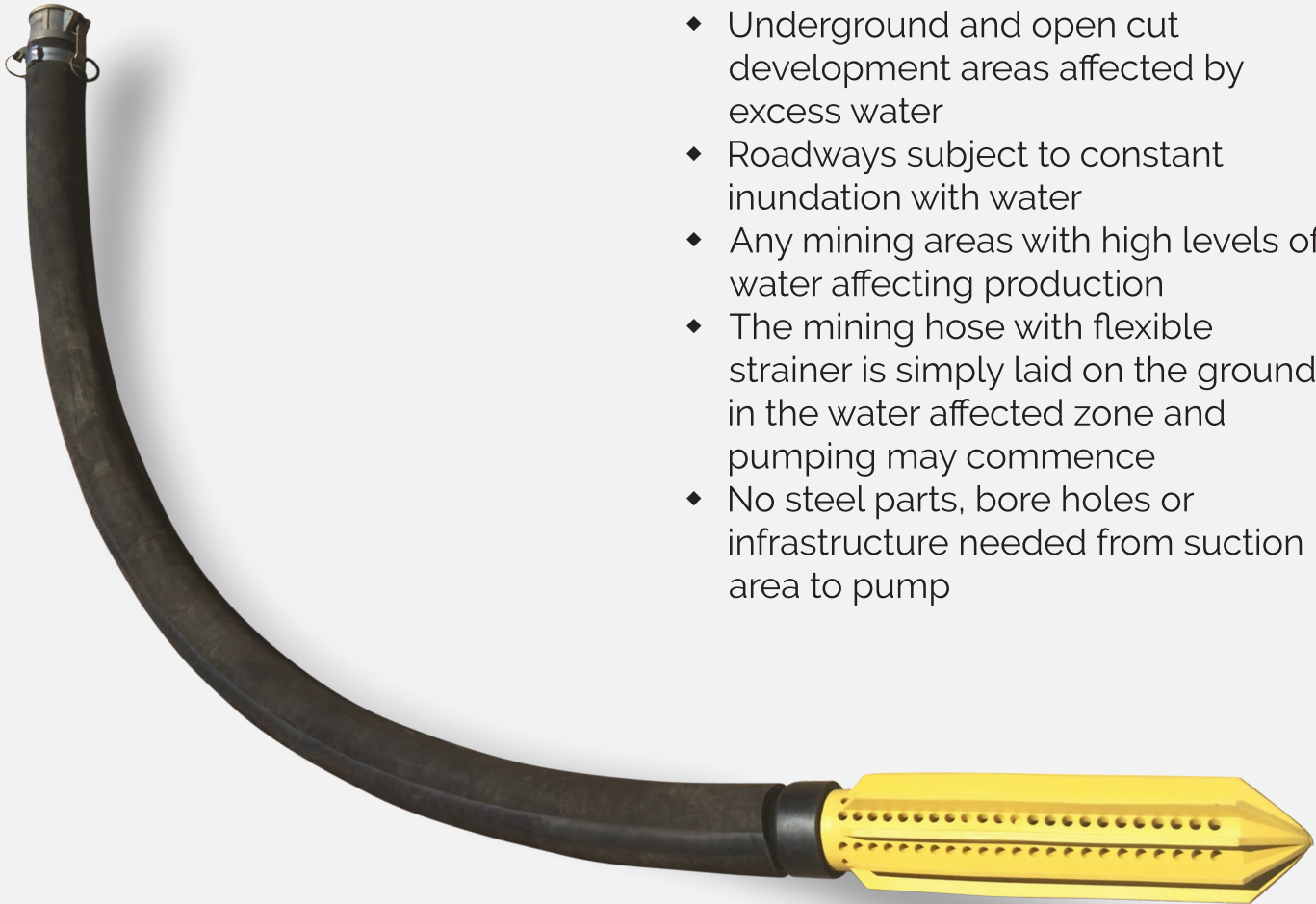

- ◆ Underground and open cut development areas affected by excess water
- ◆ Roadways subject to constant inundation with water
- ◆ Any mining areas with high levels of water affecting production
- ◆ The mining hose with flexible strainer is simply laid on the ground in the water affected zone and pumping may commence
- ◆ No steel parts, bore holes or infrastructure needed from suction area to pump

Plug and Play

Easily introduce the Reflex Suction Strainer to your existing pumping network and have no steel or plastic between the suction point and your pump.

ADDITIONAL APPLICATIONS

- 1. Domestic** – Septic tanks, grease traps, polluted water, blocked drains, swimming pools and tanks.
- 2. Mining/Quarrying** – Excess water, underground sump management, exploration drill mud, sediment tanks, wash bays and sumps.
- 3. Tunnelling and Construction** – Removal of water from high traffic dangerous locations.
- 4. General Agriculture** – Cleaning tanks, motor oil, contaminated fuel/oils and chemicals.
- 5. Irrigation** – Farmland water movement from dams, rivers and channels.
- 6. Drilling/Bore holes** – Easy to use inside bore holes with no impact from hard or saline water.
- 7. General Industrial** – Sumps and separators, wash bays, pits, fuel tanks, paints, solvent and ink, contaminated water/effluent and flooding.
- 8. Commercial** – Grease traps, septic tanks, portable toilets, toilet blocks and green waste.
- 9. Local Government** – Sewage treatment plant maintenance, sewer wells, bulk sewage and water treatment plants.
- 10. Federal Government** – Defence (military field engineers, naval general operations).
- 11. Food Processing Facilities** – Food grade and drinking water quality compound (EPDM) for use in the food processing industry for non-contamination (no rust or paint required).
- 12. Petrochemical Industries** – Resistant to fuels and oils allowing easy use and clean.
- 13. Emergency Services** – Rural and city fire services, disaster response (flooding, storms).
- 14. General Marine** – Bilge pumps (no rust and no scratching surfaces).

