

T1

Original™ Series **PLASTIC** Pumps

EOM

Engineering
Operation &
Maintenance

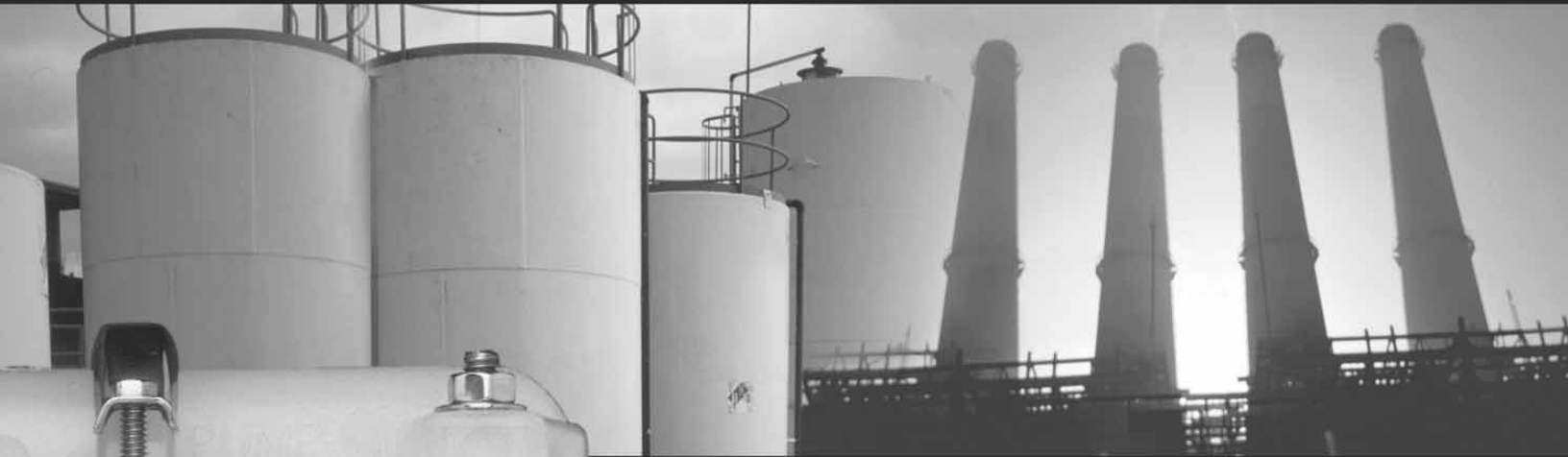

Simplify your process



TURBO-FLO™
PROGRESSIVE PUMP TECHNOLOGY

WILDEN®

A **DOVER** COMPANY

CE

WIL-10240-E-04
REPLACES WIL-10240-E-03

TABLE OF CONTENTS

	PAGE #
SECTION 1 – CAUTIONS	1
SECTION 2 – PUMP DESIGNATION SYSTEM	2
SECTION 3 – HOW IT WORKS (PUMP & AIR SYSTEMS)	3
SECTION 4 – DIMENSIONAL DRAWINGS	
A. T1 PLASTIC	4
B. T1 Ultrapure II	4
SECTION 5 – PERFORMANCE CURVES	
A. T1 PLASTIC Rubber-Fitted	5
B. T1 PLASTIC TPE-Fitted.....	5
C. T1 PLASTIC PTFE-Fitted	6
D. T1 Ultrapure II.....	6
SECTION 6 – SUCTION LIFT CURVES	7
SECTION 7 – INSTALLATION & OPERATION	
A. Installation	8
B. Operation & Maintenance	9
C. Troubleshooting Pumps	10
SECTION 8 – DIRECTIONS FOR DISASSEMBLY/REASSEMBLY	
A. T1 PLASTIC	11
B. Turbo-Flo™ Air Valve/Center Section Repair/Maintenance.....	14
C. Reassembly Hints & Tips	15
D. Gasket Kit Installation	16
SECTION 9 – EXPLODED VIEW/PARTS LISTING	
A. T1 PLASTIC Rubber/TPE-Fitted	18
B. T1 PLASTIC PTFE-Fitted	20
SECTION 10 – REFERENCE	
A. Elastomer Options.....	22



SECTION 1

T1 PLASTIC CAUTIONS – READ FIRST!



TEMPERATURE LIMITS:

Polypropylene	0°C to 79°C	32°F to 175°F
PVDF	-12°C to 107°C	10°F to 225°F
Carbon-Filled		
Acetal	-28.9°C to 65.6°C	-20°F to 150°F
PTFE PFA	-28.9°C to 148.9°C	-20°F to 300°F
Neoprene	-17.8°C to 93.3°C	0°F to 200°F
Buna-N	-12.2°C to 82.2°C	10°F to 180°F
EPDM	-51.1°C to 137.8°C	-60°F to 280°F
Viton®	-40°C to 176.7°C	-40°F to 350°F
Wil-Flex™	-40°C to 107.2°C	-40°F to 225°F
Polyurethane	12.2°C to 65.6°C	10°F to 150°F
Saniflex™	-28.9°C to 104.4°C	-20°F to 220°F
PTFE	4.4°C to 148.9°C	40°F to 300°F



CAUTION: When choosing pump materials, be sure to check the temperature limits for all wetted components. Example: Viton® has a maximum limit of 176.7°C (350°F) but polypropylene has a maximum limit of only 79°C (175°F).



CAUTION: Maximum temperature limits are based upon mechanical stress only. Certain chemicals will significantly reduce maximum safe operating temperatures. Consult engineering guide for chemical compatibility and temperature limits.



CAUTION: Always wear safety glasses when operating pump. If diaphragm rupture occurs, material being pumped may be forced out air exhaust.



WARNING: Prevention of static sparking — If static sparking occurs, fire or explosion could result. Pump, valves, and containers must be properly grounded when handling flammable fluids and whenever discharge of static electricity is a hazard.



CAUTION: Do not exceed 8.6 bar (125) psig air supply pressure.



CAUTION: Plastic series pumps are made of virgin plastic and are not UV stabilized. Direct sunlight for prolonged periods can cause deterioration of plastics.



CAUTION: Before any maintenance or repair is attempted, the compressed air line to the pump should be disconnected and all air pressure allowed to bleed from pump. Disconnect all intake, discharge and air lines. Drain the pump by turning it upside down and allowing any fluid to flow into a suitable container.



CAUTION: Blow out air line for 10 to 20 seconds before attaching to pump to make sure all pipe line debris is clear. Use an in-line air filter. A 5µ (micron) air filter is recommended.



NOTE: Tighten clamp bands and retainers prior to installation. Fittings may loosen during transportation.



NOTE: When installing PTFE diaphragms, it is important to tighten outer pistons simultaneously (turning in opposite directions) to ensure tight fit.



NOTE: Before starting disassembly, mark a line from each liquid chamber to its corresponding air chamber. This line will assist in proper alignment during reassembly.



CAUTION: Verify the chemical compatibility of the process and cleaning fluid to the pump's component materials in the Chemical Resistance Guide (see E4).



CAUTION: When removing the end cap using compressed air, the air valve end cap may come out with considerable force. Hand protection such as a padded glove or rag should be used to capture the end cap.



CAUTION: Only explosion proof (NEMA 7) solenoid valves should be used in areas where explosion proof equipment is required.



NOTE: T Series pumps must be lubricated. Wilden suggests an arctic 5 weight oil (ISO grade 15). Do not over-lubricate air supply. Over-lubrication will reduce pump performance.



NOTE: T1 Plastic PTFE-fitted pumps come standard from the factory with expanded PTFE gaskets. (See Gasket Kit Installation in Section 8E.)

SECTION 2

WILDEN PUMP DESIGNATION SYSTEM

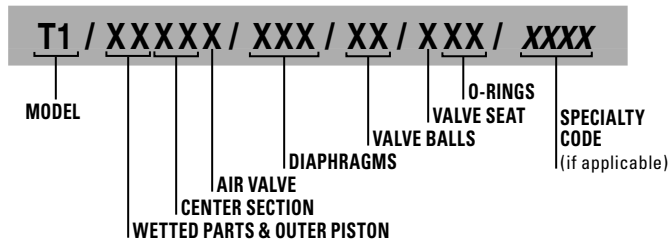

MODEL T1 PLASTIC MATERIAL CODES

WETTED PARTS & OUTER PISTON

PP = POLYPROPYLENE /
POLYPROPYLENE

CENTER SECTION

PP = POLYPROPYLENE

AIR VALVE

B = BRASS
C = PFA COATED
P = POLYPROPYLENE

DIAPHRAGMS

BNS = BUNA-N (Red Dot)
FSS = SANIFLEX™
[Hytrel® (Cream)]
PUS = POLYURETHANE (Clear)
THU = PTFE W/HIGH-TEMP BUNA-N
BACK-UP (White)
TNL = PTFE W/NEOPRENE
BACK-UP O-RING,
IPD (White)
TNU = PTFE W/NEOPRENE
BACK-UP (White)
VTS = VITON® (White Dot)
WFS = WIL-FLEX™ [Santoprene®
(Orange Dot)]

VALVE BALL

BN = BUNA-N (Red Dot)
FS = SANIFLEX™
[Hytrel® (Cream)]
PU = POLYURETHANE (Brown)
TF = PTFE (White)
VT = VITON® (White Dot)
WF = WIL-FLEX™ [Santoprene®
(Orange Dot)]

VALVE SEAT

VT = VITON® (White Dot)

VALVE SEAT O-RING

BN = BUNA-N
CR = CHEMRAZ (UPIII)
FS = SANIFLEX™
[Hytrel® (Cream)]
PU = POLYURETHANE (Brown)
TV = PTFE ENCAP. VITON®
WF = WIL-FLEX™ [Santoprene®]

SPECIALTY CODES

- | | |
|---|---|
| 0100 Wil-Gard II™ 110V | 0533 Ultrapure II, PFA coated hardware,
Wil-Gard II™ 220V, male bondable connections |
| 0102 Wil-Gard II™ sensor wires ONLY | 0560 Split manifold |
| 0103 Wil-Gard II™ 220V | 0561 Split manifold, PFA coated hardware |
| 0206 PFA coated hardware, Wil-Gard II™ sensor wires ONLY | 0563 Split manifold, discharge ONLY |
| 0300 Without air valve | 0564 Split manifold, inlet ONLY |
| 0502 PFA coated hardware | 0603 PFA coated hardware, Wil-Gard II™ 110V |
| 0520 Ultrapure II, female connections | 0608 PFA coated hardware, Wil-Gard II™ 220V |
| 0521 Ultrapure II, PFA coated hardware, female connections | 0612 Ultrapure, PFA coated hardware, male connections |
| 0522 Ultrapure II, male bondable connections | 0618 Ultrapure, PFA coated hardware, Wil-Gard II™ 110V,
male connections |
| 0523 Ultrapure II, PFA coated hardware, male bondable connections | 0622 Ultrapure, male connections |
| 0524 Ultrapure II, Wil-Gard II™ 110V, male bondable connections | 0623 Ultrapure, adapter block, no muffler, male connections |
| 0525 Ultrapure II, female connections, PFA coated hardware, Wil-Gard
II™ sensor wires ONLY | 0624 Ultrapure, Wil-Gard II™ 110V, male connections |
| 0530 Ultrapure II, female connections, Wil-Gard II™ 110V | 0660 Split manifold, Wil-Gard II™ 110V |
| 0531 Ultrapure II, female connections, Wil-Gard II™ sensor wires ONLY | 0661 Split manifold, PFA coated hardware, Wil-Gard II™ 110V |
| 0532 Ultrapure II, PFA coated hardware,
Wil-Gard II™ 110V, male bondable connections | |

NOTE: MOST ELASTOMERIC MATERIALS USE COLORED DOTS FOR IDENTIFICATION.

SECTION 3

THE WILDEN PUMP — HOW IT WORKS

The Wilden diaphragm pump is an air-operated, positive displacement, self-priming pump. These drawings show the flow pattern through the pump upon its initial stroke. It is assumed the pump has no fluid in it prior to its initial stroke.

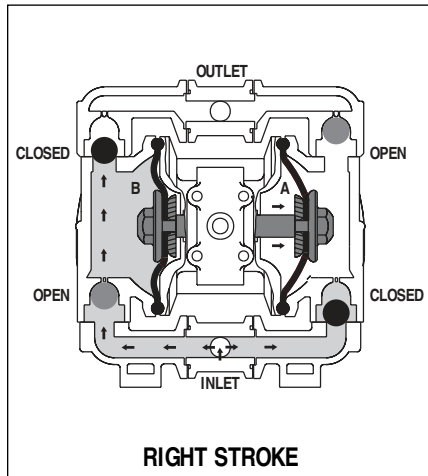

FIGURE 1 The air valve directs pressurized air to the back side of diaphragm A. The compressed air is applied directly to the liquid column separated by elastomeric diaphragms. The diaphragm acts as a separation membrane between the compressed air and liquid, balancing the load and removing mechanical stress from the diaphragm. The compressed air moves the diaphragm away from the center block of the pump. The opposite diaphragm is pulled in by the shaft connected to the pressurized diaphragm. Diaphragm B is on its suction stroke; air behind the diaphragm has been forced out to the atmosphere through the exhaust port of the pump. The movement of diaphragm B toward the center block of the pump creates a vacuum within chamber B. Atmospheric pressure forces fluid into the inlet manifold forcing the inlet valve ball off its seat. Liquid is free to move past the inlet valve ball and fill the liquid chamber (see shaded area).

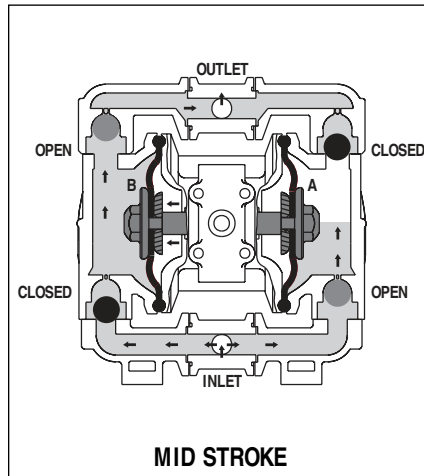

FIGURE 2 When the pressurized diaphragm, diaphragm A, reaches the limit of its discharge stroke, the air valve redirects pressurized air to the back side of diaphragm B. The pressurized air forces diaphragm B away from the center block while pulling diaphragm A to the center block. Diaphragm B is now on its discharge stroke. Diaphragm B forces the inlet valve ball onto its seat due to the hydraulic forces developed in the liquid chamber and manifold of the pump. These same hydraulic forces lift the discharge valve ball off its seat, while the opposite discharge valve ball is forced onto its seat, forcing fluid to flow through the pump discharge. The movement of diaphragm A toward the center block of the pump creates a vacuum within liquid chamber A. Atmospheric pressure forces fluid into the inlet manifold of the pump. The inlet valve ball is forced off its seat allowing the fluid being pumped to fill the liquid chamber.

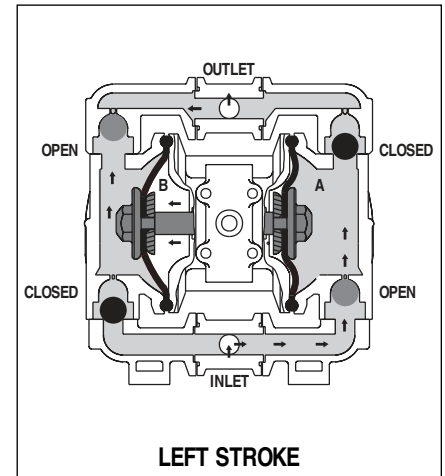
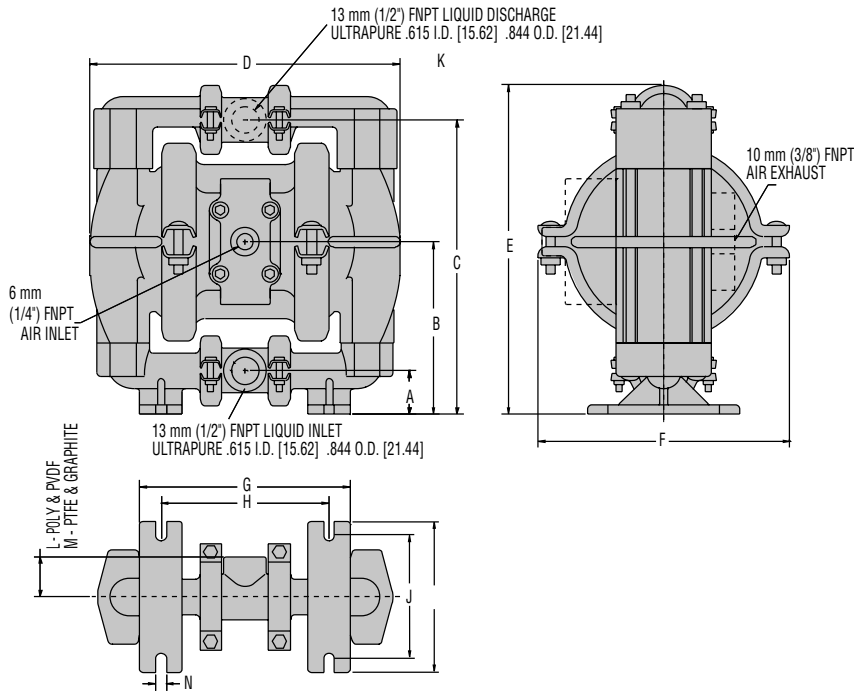

FIGURE 3 At completion of the stroke, the air valve again redirects air to the back side of diaphragm A, which starts diaphragm B on its exhaust stroke. As the pump reaches its original starting point, each diaphragm has gone through one exhaust and one discharge stroke. This constitutes one complete pumping cycle. The pump may take several cycles to completely prime depending on the conditions of the application.

SECTION 4A

DIMENSIONAL DRAWING T1 PLASTIC



DIMENSIONS

ITEM	METRIC (mm)	STANDARD (inch)
A	31	1.2
B	114	4.5
C	196	7.7
D	208	8.2
E	218	8.6
F	178	7.0
G	145	5.7
H	114	4.5
J	83	3.3
K	102	4.0
L	28	1.1
M	20	0.8
N	8	0.3

SECTION 4B

DIMENSIONAL DRAWING T1 PLASTIC ULTRAPURE II

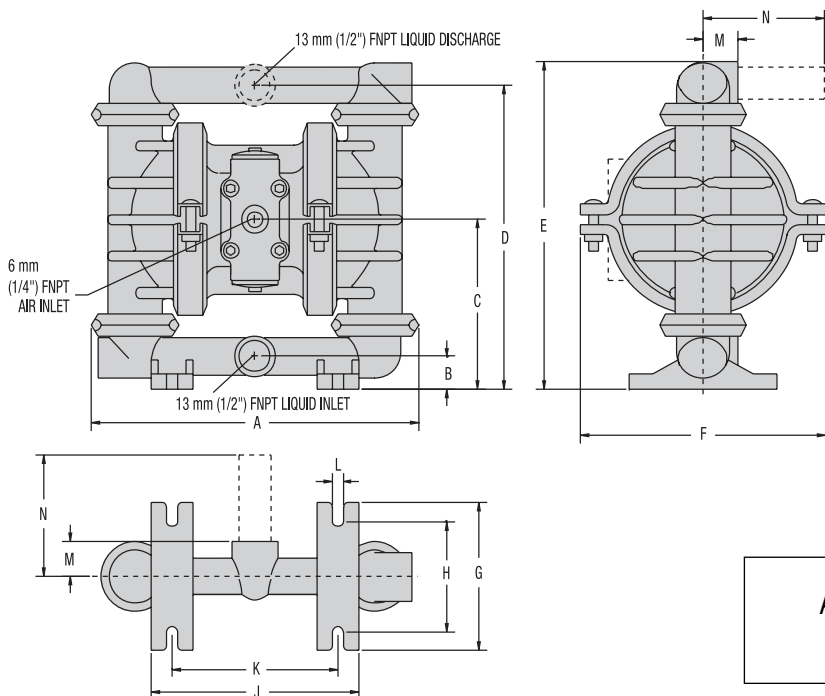

DIMENSIONS

ITEM	METRIC (mm)	STANDARD (inch)
A	226	8.9
B	23	0.9
C	122	4.8
D	213	8.4
E	229	9.0
F	173	6.8
G	102	4.0
H	76	3.0
J	142	5.6
K	114	4.5
L	6	0.3
M	25	1.0
FOR BONDABLE TEE SECTION		
N	84	3.3

All T1 Ultrapure pumps are assembled in a Class 10,000 cleanroom.

SECTION 5A

PERFORMANCE CURVES T1 PLASTIC RUBBER-FITTED

Height.....218 mm (8.6")
 Width.....208 mm (8.2")
 Depth178 mm (7.0")
 Est. Ship Weight.....Polypropylene 4 kg (9 lbs)
 Air Inlet.....6 mm (1/4")
 Inlet.....13 mm (1/2")
 Outlet13 mm (1/2")
 Suction Lift3.9 m Dry (13.0')
 9.1 m Wet (30.0')

Displacement per
 Stroke0.07 l (0.018 gal.)¹
 Max. Flow Rate.....53.4 lpm (14.1 gpm)
 Max. Size Solids1.6 mm (1/16")

¹Displacement per stroke was calculated at 4.8 bar (70 psig) air inlet pressure against a 2 bar (30 psig) head pressure.

Example: To pump 22.7 lpm (6 gpm) against a discharge pressure head of 2.7 bar (40 psig) requires 4.1 bar (60 psig) and 8.5 Nm³/h (5 scfm) air consumption. (See dot on chart.)

Caution: Do not exceed 8.6 bar (125 psig) air supply pressure.

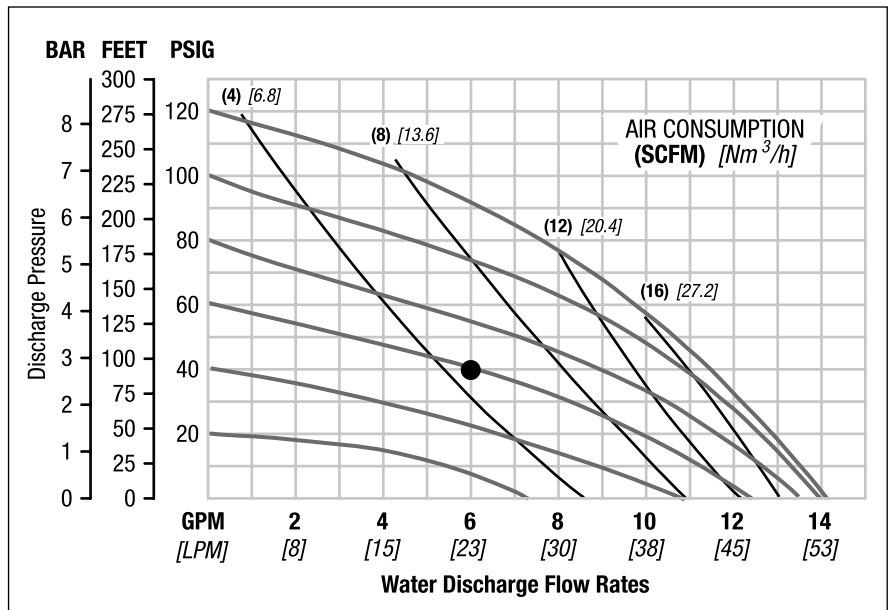

Flow rates indicated on chart were determined by pumping water.

For optimum life and performance, pumps should be specified so that daily operation parameters will fall in the center of the pump performance curve.

SECTION 5B

PERFORMANCE CURVES T1 PLASTIC TPE-FITTED

Height.....218 mm (8.6")
 Width.....208 mm (8.2")
 Depth178 mm (7.0")
 Est. Ship Weight.....Polypropylene 4 kg (9 lbs)
 Air Inlet.....6 mm (1/4")
 Inlet.....13 mm (1/2")
 Outlet13 mm (1/2")
 Suction Lift3.1 m Dry (13.0')
 9.1 m Wet (30.0')

Displacement per
 Stroke0.07 l (0.018 gal.)¹
 Max. Flow Rate.....52.2 lpm (13.8 gpm)
 Max. Size Solids1.6 mm (1/16")

¹Displacement per stroke was calculated at 4.8 bar (70 psig) air inlet pressure against a 2 bar (30 psig) head pressure.

Example: To pump 22.7 lpm (6 gpm) against a discharge pressure head of 2.7 bar (40 psig) requires 4 bar (60 psig) and 10.2 Nm³/h (6 scfm) air consumption. (See dot on chart.)

Caution: Do not exceed 8.6 bar (125 psig) air supply pressure.

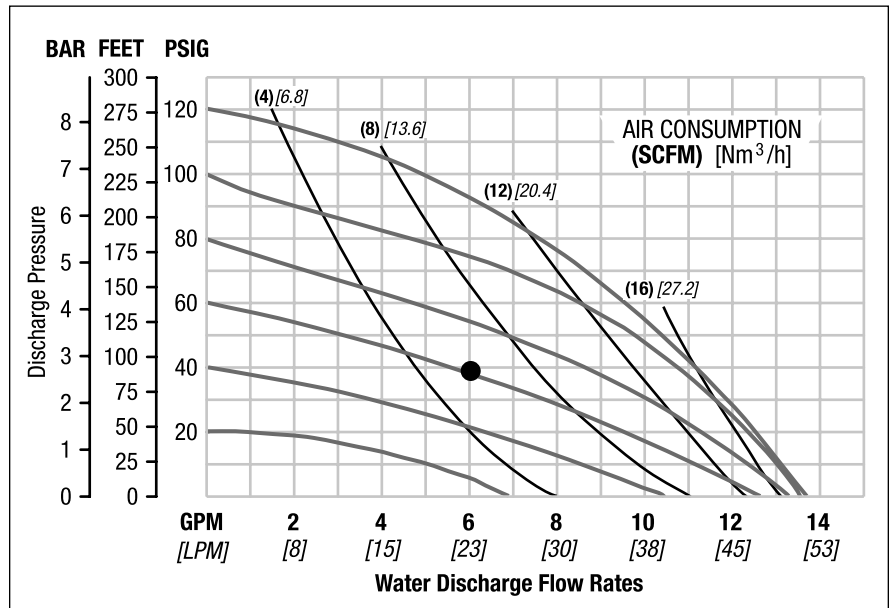

Flow rates indicated on chart were determined by pumping water.

For optimum life and performance, pumps should be specified so that daily operation parameters will fall in the center of the pump performance curve.

SECTION 5C

PERFORMANCE CURVES T1 PLASTIC PTFE-FITTED

Height.....218 mm (8.6")
 Width.....208 mm (8.2")
 Depth178 mm (7.0")
 Est. Ship Weight.....Polypropylene 4 kg (9 lbs)
 Air Inlet.....6 mm (1/4")
 Inlet13 mm (1/2")
 Outlet13 mm (1/2")
 Suction Lift3.1 m Dry (10.0')
 9.5 m Wet (31.0')

Displacement per
 Stroke0.06 l (0.015 gal.)¹
 Max. Flow Rate.....53.4 lpm (14.1 gpm)
 Max. Size Solids1.6 mm (1/16")

¹Displacement per stroke was calculated at 4.8 bar (70 psig) air inlet pressure against a 2 bar (30 psig) head pressure.

Example: To pump 18.9 lpm (5 gpm) against a discharge pressure head of 2.7 bar (40 psig) requires 4.1 bar (60 psig) and 8.5 Nm³/h (5 scfm) air consumption. (See dot on chart.)

Caution: Do not exceed 8.6 bar (125 psig) air supply pressure.

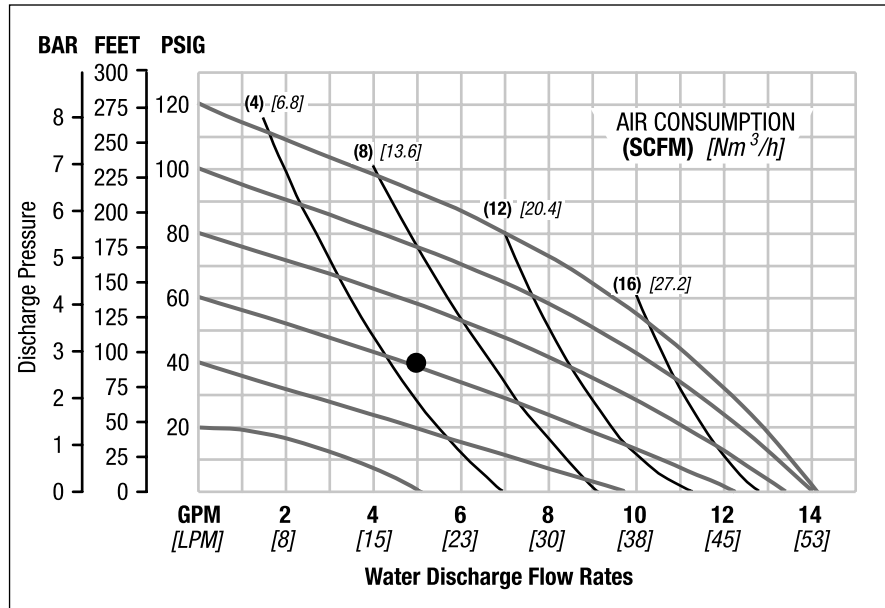

Flow rates indicated on chart were determined by pumping water.

For optimum life and performance, pumps should be specified so that daily operation parameters will fall in the center of the pump performance curve.

SECTION 5D

PERFORMANCE CURVES T1 PLASTIC ULTRAPURE II

Height.....229 mm (9.0")
 Width.....226 mm (8.9")
 Depth173 mm (6.8")
 Est. Ship Weight.....5 kg (12 lbs)
 Air Inlet.....6 mm (1/4")
 Inlet13 mm (1/2")
 Outlet13 mm (1/2")
 Suction Lift1.8 m Dry (6.0')
 9.5 m Wet (31.0')

Displacement per
 Stroke0.07 l (0.018 gal.)¹
 Max. Flow Rate.....51.1 lpm (13.5 gpm)
 Max. Size Solids3.2 mm (1/8")

¹Displacement per stroke was calculated at 4.8 bar (70 psig) air inlet pressure against a 2 bar (30 psig) head pressure.

Example: To pump 22.7 lpm (6 gpm) against a discharge pressure head of 2 bar (30 psig) requires 4.1 bar (60 psig) and 10.2 Nm³/h (6 scfm) air consumption. (See dot on chart.)

Caution: Do not exceed 8.6 bar (125 psig) air supply pressure.

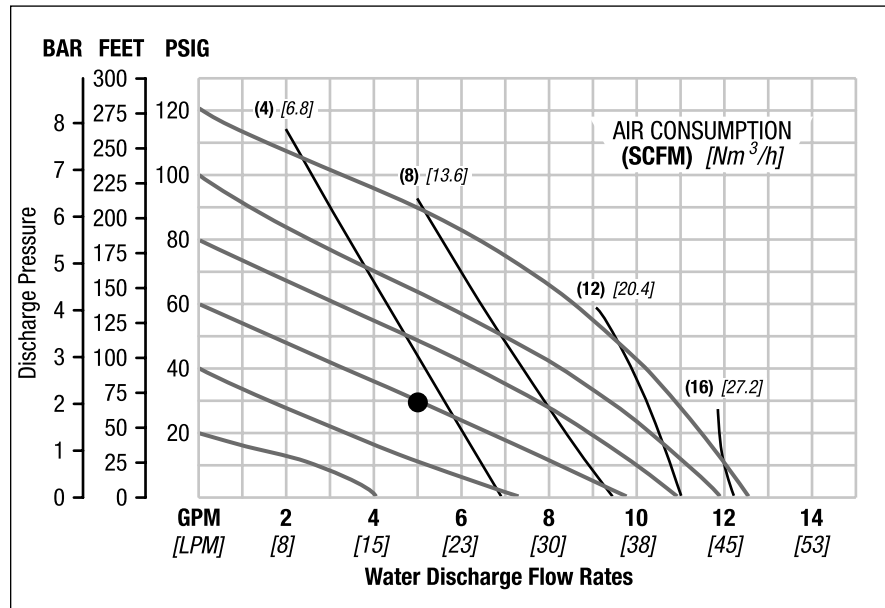

Flow rates indicated on chart were determined by pumping water.

For optimum life and performance, pumps should be specified so that daily operation parameters will fall in the center of the pump performance curve.

SECTION 6

SUCTION LIFT CURVES

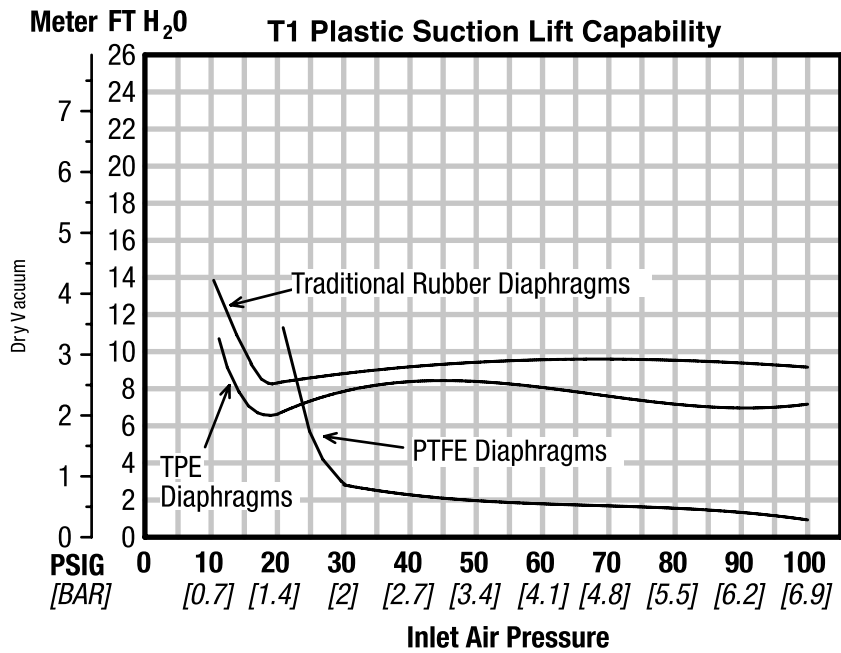

These vacuum numbers will double when a small amount of back pressure is placed on the discharge.

Suction lift curves are calibrated for pumps operating at 305 m (1,000') above sea level. This chart is meant to be a guide only. There are many variables which can affect your pump's operating characteristics. The number of intake

and discharge elbows, viscosity of pumping fluid, elevation (atmospheric pressure) and pipe friction loss all affect the amount of suction lift your pump will attain.

SECTION 7A

INSTALLATION

The Model T1 Plastic pump has a 13 mm (1/2") inlet and 13 mm (1/2") outlet and is designed for flows to 53.4 lpm (14.1 gpm). The T1 Plastic pump is manufactured with wetted parts of polypropylene. The center section of the T1 Plastic pump is of polypropylene construction. The air distribution system consists of a brass air valve body, aluminum air valve piston, Glyd™ rings and a bronze center section bushing. A variety of diaphragms, valve balls, valve seats, and o-rings are available to satisfy temperature, chemical compatibility, abrasion and flex concerns.

The suction pipe size should be at least 13 mm (1/2") diameter or larger if highly viscous material is being pumped. The suction hose must be non-collapsible, reinforced type as the T1 is capable of pulling a high vacuum. Discharge piping should be at least 13 mm (1/2"); larger diameter can be used to reduce friction losses. It is critical that all fittings and connections are airtight or a reduction or loss of pump suction capability will result.

INSTALLATION: Months of careful planning, study, and selection efforts can result in unsatisfactory pump performance if installation details are left to chance.

Premature failure and long term dissatisfaction can be avoided if reasonable care is exercised throughout the installation process.

LOCATION: Noise, safety, and other logistical factors usually dictate that "utility" equipment be situated away from the production floor. Multiple installations with conflicting requirements can result in congestion of utility areas, leaving few choices for siting of additional pumps.

Within the framework of these and other existing conditions, every pump should be located in such a way that four key factors are balanced against each other to maximum advantage.

ACCESS: First of all, the location should be accessible. If it's easy to reach the pump, maintenance personnel will have an easier time carrying out routine inspections and adjustments. Should major repairs become necessary, ease of access can play a key role in speeding the repair process and reducing total downtime.

AIR SUPPLY: Every pump location should have an air line large enough to supply the volume of air necessary to achieve the desired pumping rate (see pump performance chart). Use air pressure up to a maximum of 8.6 bar (125 psig) depending upon pumping requirements. The use of an air filter before the pump will ensure that the majority of any pipeline contaminants will be eliminated. For best results, the pumps should use an air filter, regulator, and lubricator system.

ELEVATION: Selecting a site that is well within the pump's suction lift capability will assure that loss-of-prime troubles will be eliminated. In addition, pump efficiency can be adversely affected if proper attention is not given to elevation (see pump performance chart).

PIPING: Final determination of the pump site should not be made until the piping problems of each possible location have been evaluated. The impact of current and future installations should be considered ahead of time to make sure that inadvertent restrictions are not created for any remaining sites.

The best choice possible will be a site involving the shortest and the straightest hook-up of suction and discharge piping. Unnecessary elbows, bends, and fittings should be avoided. Pipe sizes should be selected so as to keep friction losses within practical limits. All piping should be supported independently of the pump. In addition, it should line up without placing stress on the pump fittings.

Expansion joints can be installed to aid in absorbing the forces created by the natural reciprocating action of the pump. If the pump is to be bolted down to a solid foundation, a mounting pad placed between the pump and foundation will assist in minimizing pump vibration. Flexible connections between the pump and rigid piping will also assist in minimizing pump vibration. If quick-closing valves are installed at any point in the discharge system, or if pulsation within a system becomes a problem, a surge suppressor should be installed to protect the pump, piping and gauges from surges and water hammer.

When pumps are installed in applications involving flooded suction or suction head pressures, a gate valve should be installed in the suction line to permit closing of the line for pump service.

The T1 can be used in submersible applications only when both wetted and non-wetted portions are compatible with the material being pumped. If the pump is to be used in a submersible application, a hose should be attached to the pump's air exhaust and the exhaust air piped above the liquid level.

If the pump is to be used in a self-priming application, be sure that all connections are airtight and that the suction lift is within the pump's ability. Note: Materials of construction and elastomer material have an effect on suction lift parameters. Please refer to pump performance data.

Pumps in service with a positive suction head are most efficient when inlet pressure is limited to 0.5–0.7 bar (7–10 psig). Premature diaphragm failure may occur if positive suction is 0.8 bar (11 psig) and higher.

THE MODEL T1 WILL PASS 1.6 mm (1/16") SOLIDS. WHENEVER THE POSSIBILITY EXISTS THAT LARGER SOLID OBJECTS MAY BE SUCKED INTO THE PUMP, A STRAINER SHOULD BE USED ON THE SUCTION LINE.

CAUTION: DO NOT EXCEED 8.6 BAR (125 PSIG) AIR SUPPLY PRESSURE.

BLOW OUT AIR LINE FOR 10 TO 20 SECONDS BEFORE ATTACHING TO PUMP TO MAKE SURE ALL PIPE LINE DEBRIS IS CLEAR. ALWAYS USE AN IN-LINE AIR FILTER.

PUMPS SHOULD BE THOROUGHLY FLUSHED WITH WATER BEFORE INSTALLING INTO PROCESS LINES.

SUGGESTED INSTALLATION

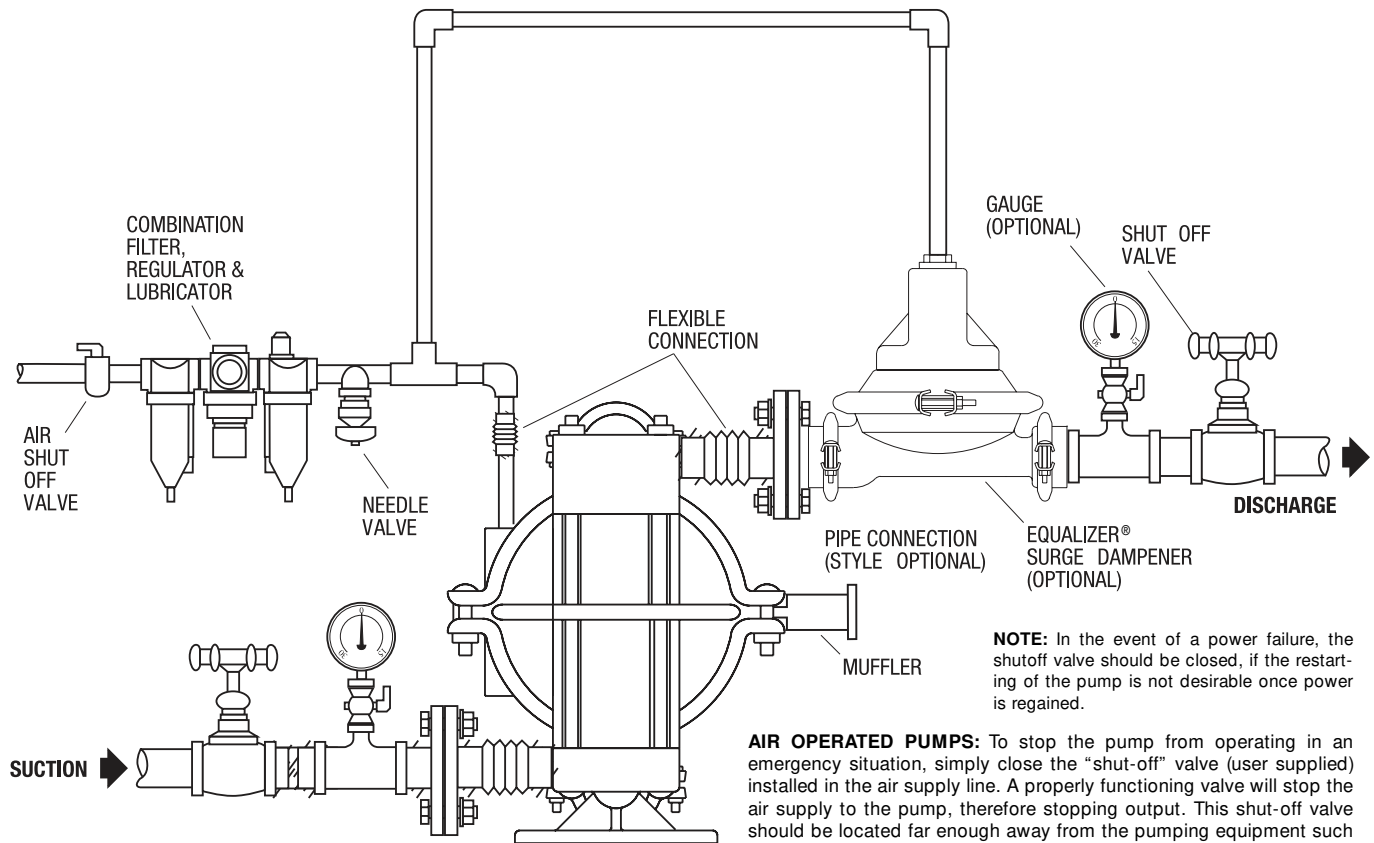

SECTION 7B

SUGGESTED OPERATION AND MAINTENANCE INSTRUCTIONS

OPERATION: Pump discharge rate can be controlled by limiting the volume and/or pressure of the air supply to the pump (preferred method). An air regulator is used to regulate air pressure. A needle valve is used to regulate volume. Pump discharge rate can also be controlled by throttling the pump discharge by partially closing a valve in the discharge line of the pump. This action increases friction loss which reduces flow rate. This is useful when the need exists to control the pump from a remote location. When the pump discharge pressure equals or exceeds the air supply pressure, the pump will stop; no bypass or pressure relief valve is needed, and pump damage will not occur. The pump has reached a "deadhead" situation and can be restarted by reducing the fluid discharge pressure or increasing the air inlet pressure. The Wilden T1 pump runs solely on compressed air and does not generate heat, therefore your process fluid temperature will not be affected.

RECORDS: When service is required, a record should be made of all necessary repairs and replacements. Over a period of time, such records can become a valuable tool for predicting and preventing future maintenance problems and unscheduled downtime. In addition, accurate records make it possible to identify pumps that are poorly suited to their applications.

MAINTENANCE AND INSPECTIONS: Since each application is unique, maintenance schedules may be different for every pump. Frequency of use, line pressure, viscosity and abrasiveness of process fluid all affect the parts life of a Wilden pump. Periodic inspections have been found to offer the best means for preventing unscheduled pump downtime. Personnel familiar with the pump's construction and service should be informed of any abnormalities that are detected during operation.

SECTION 7C

TROUBLESHOOTING

Pump will not run or runs slowly.

1. Check air inlet screen and air filter for debris.
2. Check for sticking air valve, flush air valve in solvent.
3. Check for worn out air valve. If piston face in air valve is shiny instead of dull, air valve is probably worn beyond working tolerances and must be replaced.
4. Check center block o-rings. If worn excessively, they will not seal and air will simply flow through pump and out air exhaust. Use only Wilden o-rings as they are of special construction and ISO 15-5 wt oil with arctic characteristics.
5. Check for rotating piston in air valve.

Pump runs but little or no product flows.

1. Check for pump cavitation; slow pump speed down to match thickness of material being pumped.
2. Check for sticking ball check valves. If material being pumped is not compatible with pump elastomers, swelling may occur. Replace ball check valves and o-ring with the proper elastomers.
3. Check to make sure all suction connections are air tight, especially clamp bands around intake balls.

Pump air valve freezes.

1. Check for excessive moisture in compressed air. Either install dryer or hot air generator for compressed air.

Air bubbles in pump discharge.

1. Check for ruptured diaphragm.
2. Check tightness of clamp bands, and the integrity of the o-rings, especially at intake manifold.

Product comes out air exhaust.

1. Check for diaphragm rupture.
2. Check tightness of piston plates to shaft.

Pump rattles.

1. Create false discharge head or suction lift.

SECTION 8A

MODEL T1 PLASTIC DIRECTIONS FOR DISASSEMBLY/REASSEMBLY

CAUTION: Before any maintenance or repair is attempted, the compressed air line to the pump should be disconnected and all air pressure allowed to bleed from the pump. Disconnect all intake, discharge, and air lines. Drain the pump by turning it upside down and allowing any fluid to flow into a suitable container. Be aware of any hazardous effects of contact with your process fluid.

The Wilden model T1 has a 13 mm (1/2") inlet and outlet and is designed for flows up to 53.4 lpm (14.1 gpm). The single-piece center section, consisting of center block and air chambers, is molded of polypropylene. All fasteners and hardware are stainless steel and the air valve is manufactured of brass or high-tech engineered thermoplastic. Its air distribution system is based on a time-proven design, which offers economical reliability and performance. The model T1 Plastic is available in injection-molded polypropylene wetted parts.

TOOLS REQUIRED:

8 mm (5/16") Wrench

5 mm (3/16") Allen Wrench

10 mm (3/8") Wrench

11 mm (7/16") Wrench

Adjustable Wrench

Vise equipped with soft jaws (such as plywood, plastic or other suitable material)

NOTE: The model used for these instructions incorporates rubber diaphragms, balls, and seats. Models with PTFE diaphragms, balls and seats are the same except where noted.

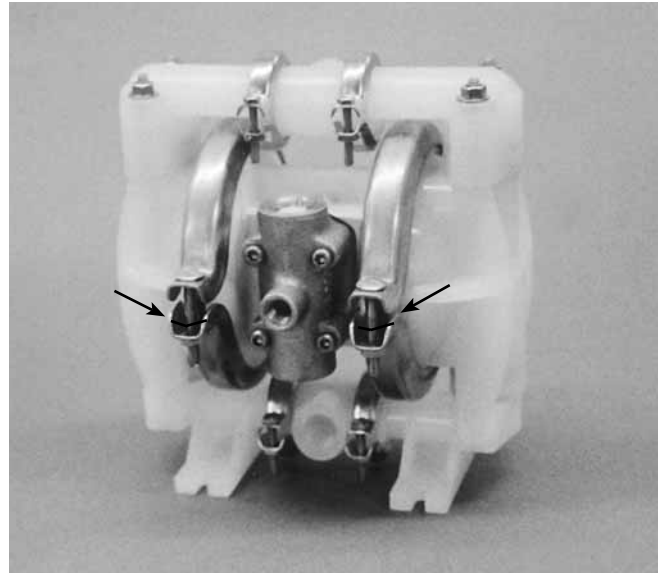

DISASSEMBLY:

Figure 1

Step 1

Before starting disassembly, mark a line from each liquid chamber to its corresponding air chamber. This line will assist in proper alignment during reassembly.

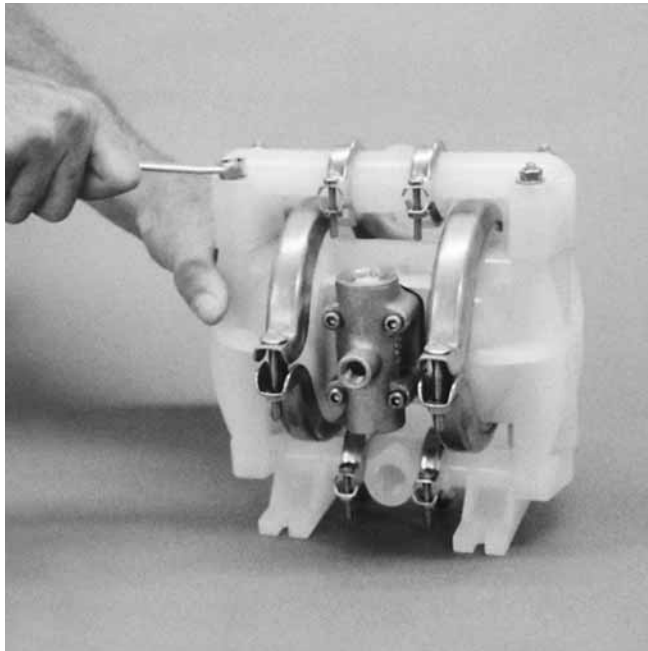

Step 2

Figure 2

Utilizing the 10 mm (3/8") box wrench, start by removing the four long carriage bolts that hold the top and bottom manifolds to the center section.

WIL-10240-E-04

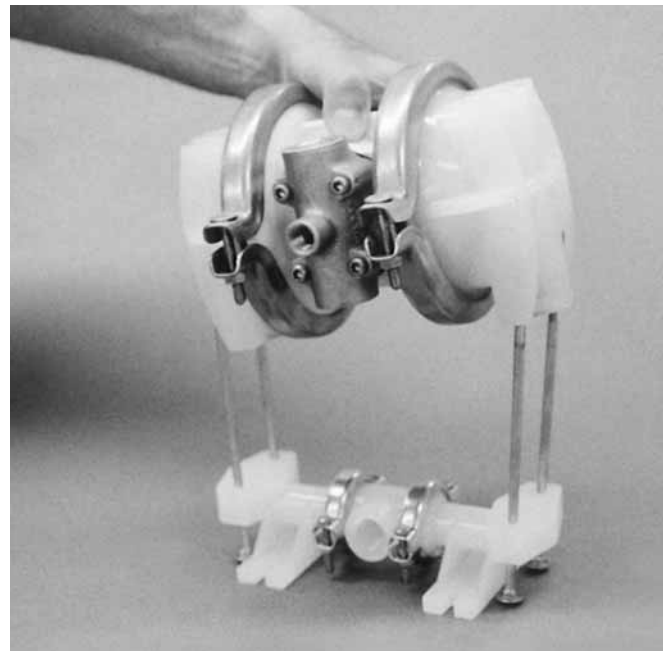

Step 3

Figure 3

Remove the top manifold and lift the center section off the inlet manifold.

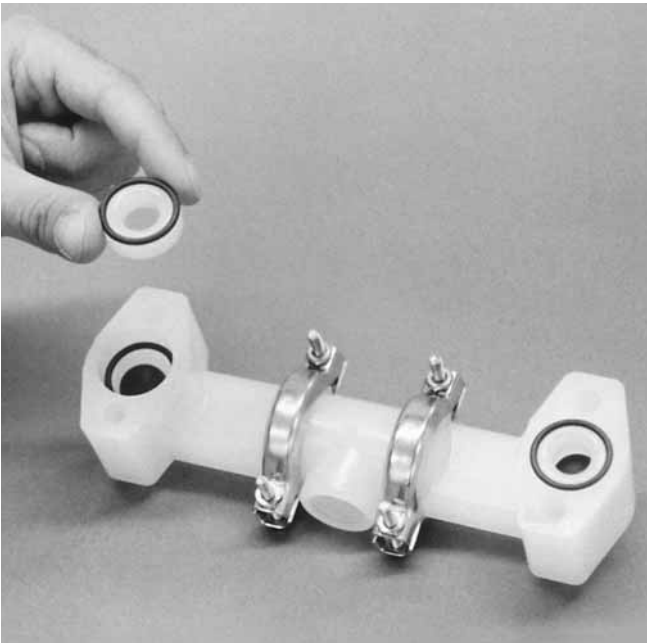

Step 4 *Figure 4*

Remove the discharge valve balls, seats and o-rings from the discharge manifold and inspect for nicks, gouges, chemical attack or abrasive wear. Replace worn parts with genuine Wilden parts for reliable performance. PTFE o-rings should be replaced when reassembled.

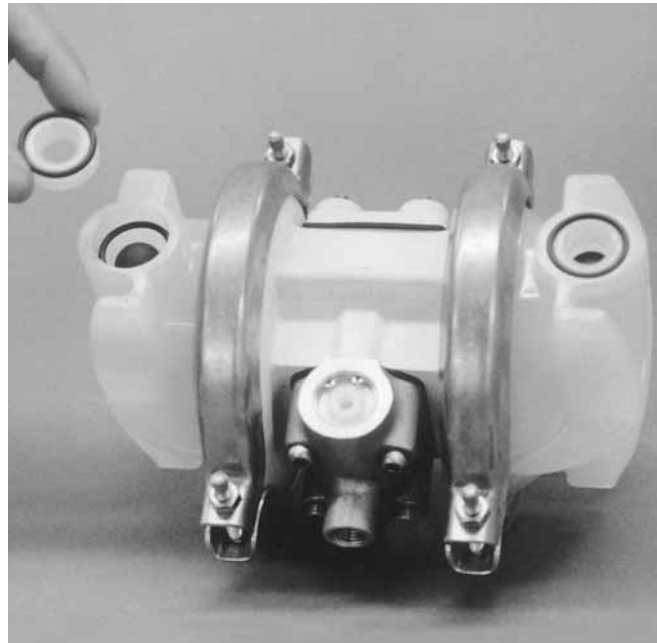

Step 5 *Figure 5*

Remove and inspect the ball retainer, retainer o-ring, and valve ball from the bottom of the liquid chamber. Check for nicks, gouges, chemical attack or abrasive wear. Replace worn parts with genuine Wilden parts for reliable performance. PTFE o-rings should be replaced when reassembled.

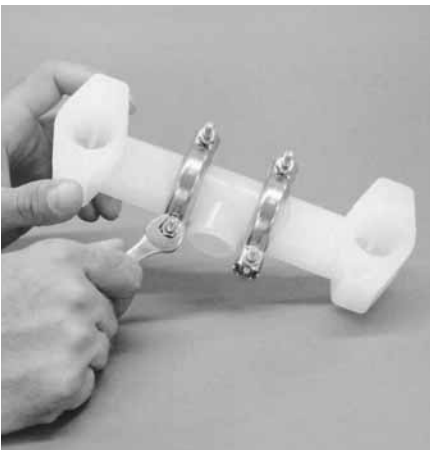

Step 6 *Figure 6*

Normally the inlet and discharge manifold should not be disassembled during regular pump maintenance. Should this be necessary completely remove and disassemble manifold clamp bands.



Step 7 *Figure 7*

Inspect o-rings for wear or damage and replace if necessary. PTFE o-rings should be replaced when reassembled.

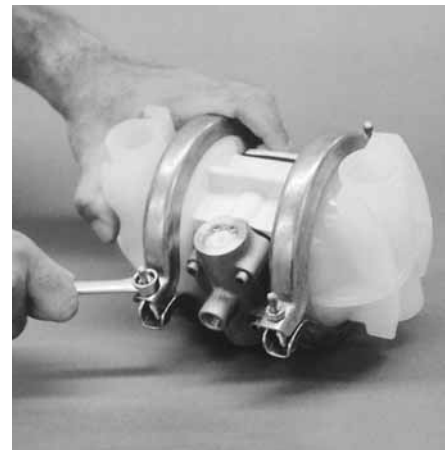

Step 8 *Figure 8*

Use a 11 mm (7/16") wrench to remove one set of clamp bands that secure one liquid chamber to the one-piece center section.

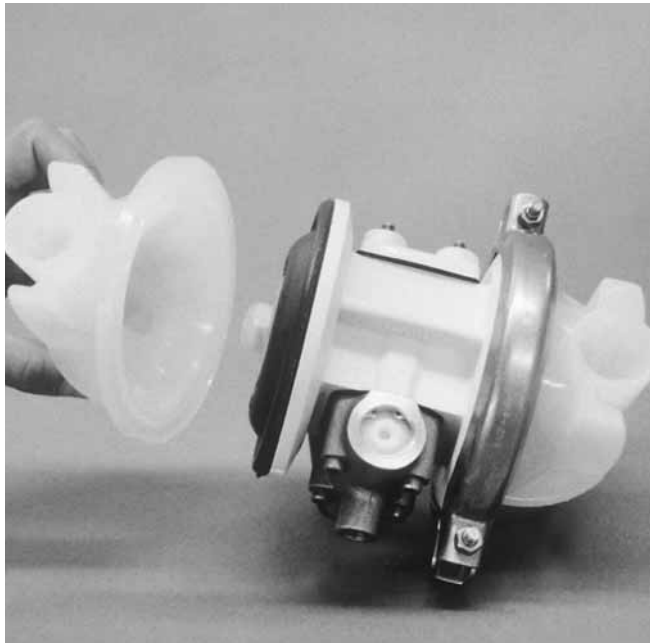

Step 9 *Figure 9*

Lift the liquid chamber away from the center section to expose the diaphragm and outer piston.



Step 10 *Figure 10*

Using an adjustable wrench, or by rotating the diaphragm by hand, remove the diaphragm assembly from the center section.



Step 11A *Figure 11A*

NOTE: Due to varying torque values, one of the following two situations may occur: 1) The outer piston, diaphragm and inner piston remain attached to the shaft and the entire assembly can be removed from the center section.



Step 11B *Figure 11B*

2) The outer piston, diaphragm, inner piston, and disc spring separate from the shaft which remains connected to the opposite side diaphragm assembly. PTFE-fitted pumps come standard with back-up diaphragms (not shown). **NOTE:** Disc spring not shown on *Figure 11B*.

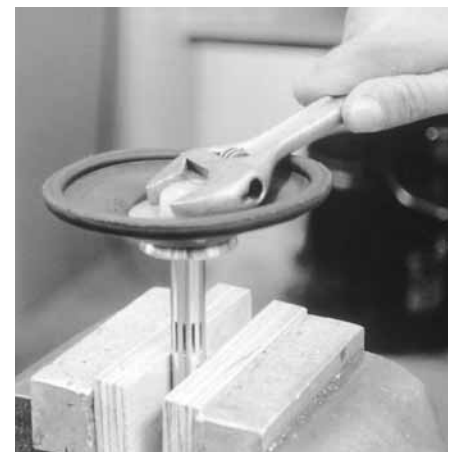

Step 12 *Figure 12*

To remove the diaphragm assembly from the shaft, secure shaft with soft jaws (a vise fitted with plywood or other suitable material) to ensure shaft is not nicked, scratched, or gouged. Using an adjustable wrench, remove diaphragm assembly from shaft. Inspect all parts for wear and replace with genuine Wilden parts if necessary.

SECTION 8B

AIR VALVE / CENTER SECTION REPAIR / MAINTENANCE

The center section assembly consists of both the air valve body and piston and the center section. The unique design of the air valve relies only on differential pressure to cause the air valve to shift. It is reliable and simple to maintain. The bushing in the center block, along with the diaphragm shaft, provides the signal to tell the air valve to shift. The following procedure will ensure that the air valve on your Wilden pump will provide long trouble-free service.

AIR VALVE BODY AND PISTON ASSEMBLY AND DISASSEMBLY

The air valve body and piston (P/N 01-2000-07) can be disconnected from the pump by removing the four socket-head cap screws which attach it to the center section. The piston in the air valve is aluminum with a dark gray anodized coating. The piston should move freely and the ports in the piston should line up with the ports on the face of the air valve body. The piston should also appear to be a dull, dark gray color. If the piston appears to be a shiny aluminum color, the air valve is probably worn beyond working tolerances and should be replaced.

If the piston does not move freely in the air valve, the entire air valve should be immersed in a cleaning solution. (NOTE: Do not force the piston by inserting a metal object.) This soaking should remove any accumulation of sludge and grit which is preventing the air valve piston from moving freely. If the air valve piston does not move freely after the above

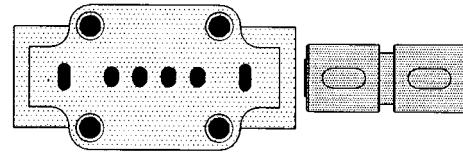

Figure A

cleaning, the air valve should be disassembled as follows: Remove the snap ring from the top end of the air valve cylinder and apply an air jet to the 1/8-inch hole on the opposite end of the air valve face. **[CAUTION: The air valve end cap (P/N 01-2330-23 may come out with considerable force. Hand protection such as a padded glove or a rag should be used to capture the end cap.)** Inspect the piston and cylinder bore for nicks and scoring.

Inspect the air valve side of the center section for flatness and to insure no nicks or other damage exists that would prevent the air valve from sealing when installed. Inspect the two channels and their ports to make sure they are clean and the ports are open to the bushing. The air valve will not shift if these ports are plugged or an o-ring is in the wrong groove of the center section closing off a port. Inspect the anti-centering pin holes found at the ends of the air valve piston and ensure they are free of debris. Inspect the air valve gasket and muffler plate gasket and replace if damaged. **Attach the air valve to the center section and tighten to the required torque specifications*.**

O-RING REPLACEMENT/ CENTER SECTION

The pump's center section consists of a molded housing with a bronze bushing. (Bushing is not removable.) This bushing has grooves cut into the inside diameter. o-rings are installed in these grooves. When the o-rings become worn or flat, they will no longer seal and must be replaced. This is most easily accomplished by using a tool called an o-ring pick, available through most industrial supply companies.

There are two versions of center sections: PRE-ENHANCED (pumps manufactured before March 1, 1992) and ENHANCED (pumps manufactured since March 1, 1992). An encircled letter "E" stamped on the top of the center section denotes the ENHANCED type center section (Figure C).

If the encircled "E" is not present, a pre-enhanced shaft (01-3800-09) must be utilized. An enhanced (non-dented) shaft will not function correctly in the pre-enhanced center section. The center section o-rings (01-3200-52) must be installed in the appropriate grooves as shown (1, 3, 4, 6).

If the encircled "E" is present, an enhanced (01-3800-03-07) shaft should be utilized to maximize performance. The center section o-rings (01-3200-52) must be installed in the appropriate grooves as shown (1, 3, 6, 8).

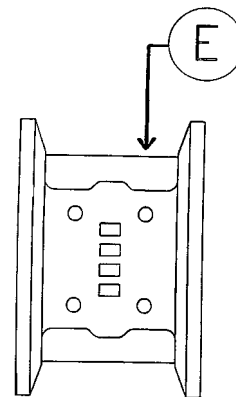
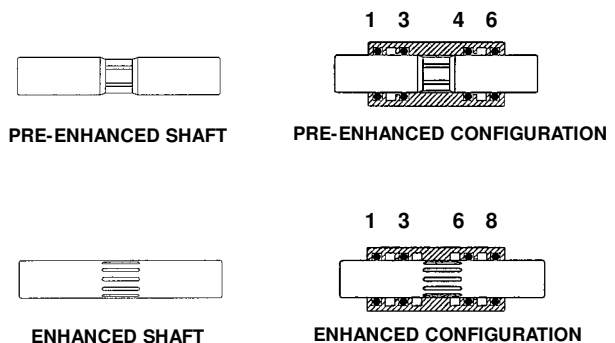

Figure C



*Refer to Section 8D for the required torque specifications.

SECTION 8C

REASSEMBLY HINTS & TIPS

ASSEMBLY:

Upon performing applicable maintenance to the air distribution system, the pump can now be reassembled. Please refer to the disassembly instructions for photos and parts placement. To reassemble the pump, follow the disassembly instructions in reverse order. The air distribution system needs to be assembled first, then the diaphragms and finally the wetted path. Please find the applicable torque specifications on this page. The following tips will assist in the assembly process.

- Clean the inside of the center section shaft bushing to ensure no damage is done to new seals.
- Stainless bolts should be lubed to reduce the possibility of seizing during tightening.
- Level the water chamber side of the intake/discharge manifold to ensure a proper sealing surface. This is most easily accomplished by placing them on a flat surface prior to tightening their clamp bands to the desired torque (see this page for torque specs).
- Be sure to tighten outer pistons simultaneously on PTFE-fitted pumps to ensure proper torque values.
- Ensure proper mating of liquid chambers to manifolds prior to tightening vertical bolts. Overhang should be equal on both sides.
- Apply a small amount of Loctite 242 to the steel bore of the shaft from the diaphragm assembly.

MAXIMUM TORQUE SPECIFICATIONS

Description of Part	Plastic Pumps
Air Valve	2.3 N•m (20 in-lbs)
Outer Piston	14.1 N•m (125 in-lbs)
Small Clamp Band	1.7 N•m (15 in-lbs)
Large Clamp Band (Rubber-fitted)	7.3 N•m (65 in-lbs)
Large Clamp Band (PTFE-fitted)	9.6 N•m (85 in-lbs)
Vertical Bolts	9.0 N•m (80 in-lbs)

SECTION 8D

GASKET KIT INSTALLATION

T1 PVDF and Ultrapure II and pumps come standard with expanded PTFE Gasket Kits (P/N 01-9501-99) for all sealing surfaces. T1 Poly pumps come standard with expanded PTFE Gasket Kits (P/N 01-9500-99) for diaphragm bead only. Carefully prepare sealing surfaces by removing all debris and

foreign matter from diaphragm bead and all mating surfaces. If necessary, smooth or deburr all sealing surfaces. Mating surfaces must be properly aligned in order to ensure positive sealing characteristics.

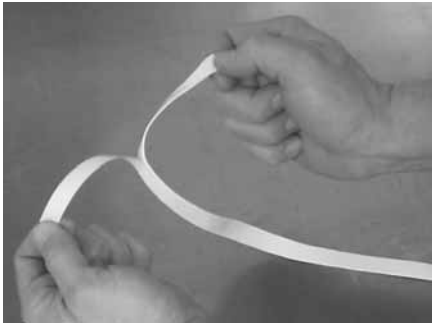

Step 1. *Figure 1*

Gently remove the adhesive covering from the back of the PTFE tape. Ensure that the adhesive strip remains attached to the PTFE tape and is not removed with the adhesive covering.



Step 2. *Figure 2*

Starting at any point, place the PTFE tape directly on top of the diaphragm bead. Press lightly on the tape to ensure that the adhesive holds it in place during assembly. Do not stretch the tape during placement on the diaphragm bead.



Step 3. *Figure 3*

The ends of the tape should overlap approximately 13 mm (1/2") (*Figure 3*). Proceed to install the PTFE tape on the remaining diaphragm.



Step 4. *Figure 4*

Carefully remove the protective covering from the back of the PTFE gasket attached to tape.



Step 5. *Figure 5*

Install the valve ball, valve seat and o-ring.



Step 6. *Figure 6*

Center the gasket so that it evenly covers the o-ring and seat areas.



Step 7. *Figure 7*

Gently apply pressure to gasket to ensure the adhesive maintains a positive seal to stay in place during pump assembly.

Finding spares a nightmare?

Sleep easier with



PRODUCTS:

AODDP

(Air Operated Double Diaphragm Pumps)

- Warren-Rupp
- ARO
- Other

PUMP PARTS

(Low Cost)



- Diaphragms
- Valve balls
- Valve seats

KNOWLEDGE & SERVICE



- Competitive pricing
- Delivery
- Service
- Inventory

Spectrom is not your typical after market part supplier. We do not simply sell pump parts; we provide value added procurement solutions.

Our unique network enables us to purchase effectively, resulting in low cost solutions. We also know that low purchase price is not enough - quality, integrity and inventory are also important. Spectrom is structured to provide Pre and Post sales support, giving our customers value added application and pump knowledge.

Contact us to have a procurement solution developed for you. We don't just fit you into a generic system, we develop specific solutions that achieve results.

Spectrom will ship your order from our facility within 3 working days!

WARNING These parts may exhibit better life than OEM parts.

1-909-512-1261



www.spectromparts.com

SECTION 9A

EXPLODED VIEW/PARTS LISTING

T1 PLASTIC RUBBER/TPE FITTED

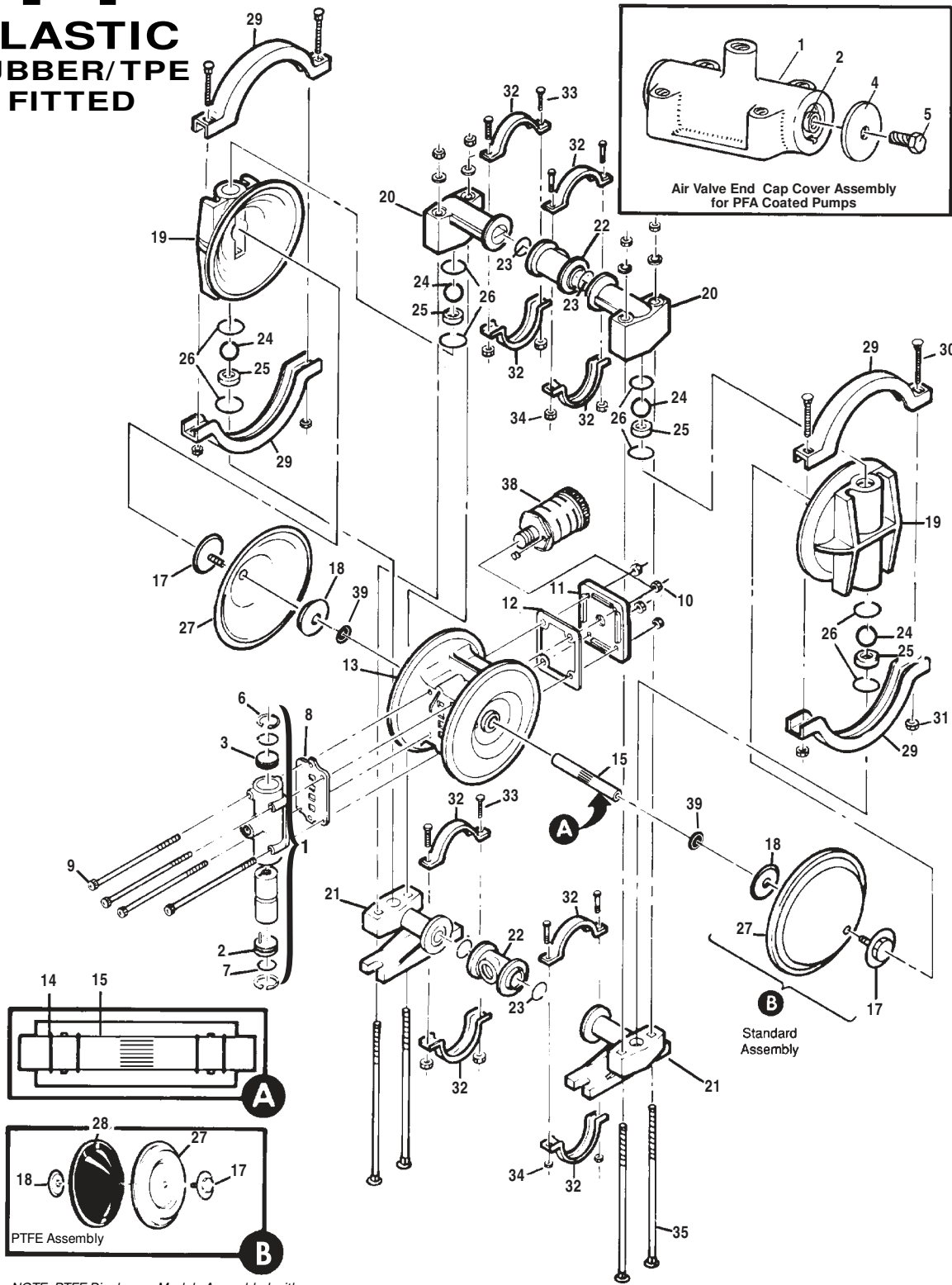

NOTE: PTFE Diaphragm Models Assembled with PTFE Gasket Kit At Factory (Not Shown)

T1 RUBBER/TPE-FITTED

Item	Part Description	Qty. Per Pump	T1/PPPPB P/N	T1/PPPPC/0502 P/N
1	Air Valve Assembly	1	01-2000-07	01-2000-05
2	Air Valve End Cap w/Guide (Top)	1	01-2300-23	01-2300-23
3	Air Valve End Cap w/o Guide (Bottom)	1	01-2330-23	01-2330-23
4	Air Valve End Cap Cover	2	N/A	01-2420-55
5	Air Valve End Cap Bolt	2	N/A	01-2450-22
6	Snap Ring	2	01-2650-03	01-2650-03
7	Buna-N O-Ring - 115 70 Shore	2	01-2390-52	01-2390-52
8	Air Valve Gasket	1	01-2600-52	01-2600-52
9	Air Valve Screw	4	01-6000-03	01-6000-05
10	Air Valve Screw Nut	4	04-6400-03	04-6400-05
11	Muffler Plate	1	01-3180-20	01-3180-20
12	Muffler Plate Gasket	1	01-3500-52	01-3500-52
13	Center Section	1	01-3152-20	01-3152-20
14	Center Block Glyd™ Ring	4	01-3220-55	01-3220-55
15	Shaft	1	01-3800-03-07	01-3800-03-07
16	Shaft Stud ¹	2	N/A	N/A
17	Piston, Outer	2	01-4570-20-500	01-4570-20-500
18	Piston, Inner	2	01-3710-01	01-3710-01
19	Liquid Chamber	2	01-5000-20	01-5000-20
20	Discharge Manifold Elbow	2	01-5230-20	01-5230-20
21	Inlet Manifold Elbow	2	01-5220-20	01-5220-20
22	Manifold Tee Section (Female, Threaded)	2	01-5160-20	01-5160-20
23	Manifold O-Ring	4	*	*
24	Valve Ball	4	*	*
25	Valve Seats	4	01-1120-21-500	01-1120-21-500
26	Valve Seat O-Ring	8	*	*
27	Diaphragm	2	*	*
28	Back-up Diaphragm	2	N/A	N/A
29	Large Clamp Band	2	01-7300-03	01-7300-05
30	Large Clamp Band Bolt	4	01-6070-03	01-6070-05
31	Large Clamp Band Nut	4	04-6400-03	04-6400-05
32	Small Clamp Band	4	01-7100-03	01-7100-05
33	Small Clamp Band Bolt 1"	8	01-6101-03	01-6101-05
34	Small Clamp Band Nut	8	01-6400-03	01-6400-05
35	Vertical Bolt	4	01-6080-03	01-6080-05
36	Vertical Bolt Nut	4	04-6400-03	04-6400-05
37	Vertical Bolt Washer	4	01-6730-03	01-6730-05
38	Muffler	1	01-3510-99	01-3510-99
39	Disc Spring	2	01-6802-08	01-6802-08

¹Shaft stud is molded into outer piston on all plastic pumps.

*Refer to corresponding elastomer chart at end of section.

0502 Specialty Code = PFA-Coated Hardware

All boldface items are primary wear parts.

SECTION 9B

EXPLODED VIEW/PARTS LISTING

T1 PLASTIC PTFE- FITTED

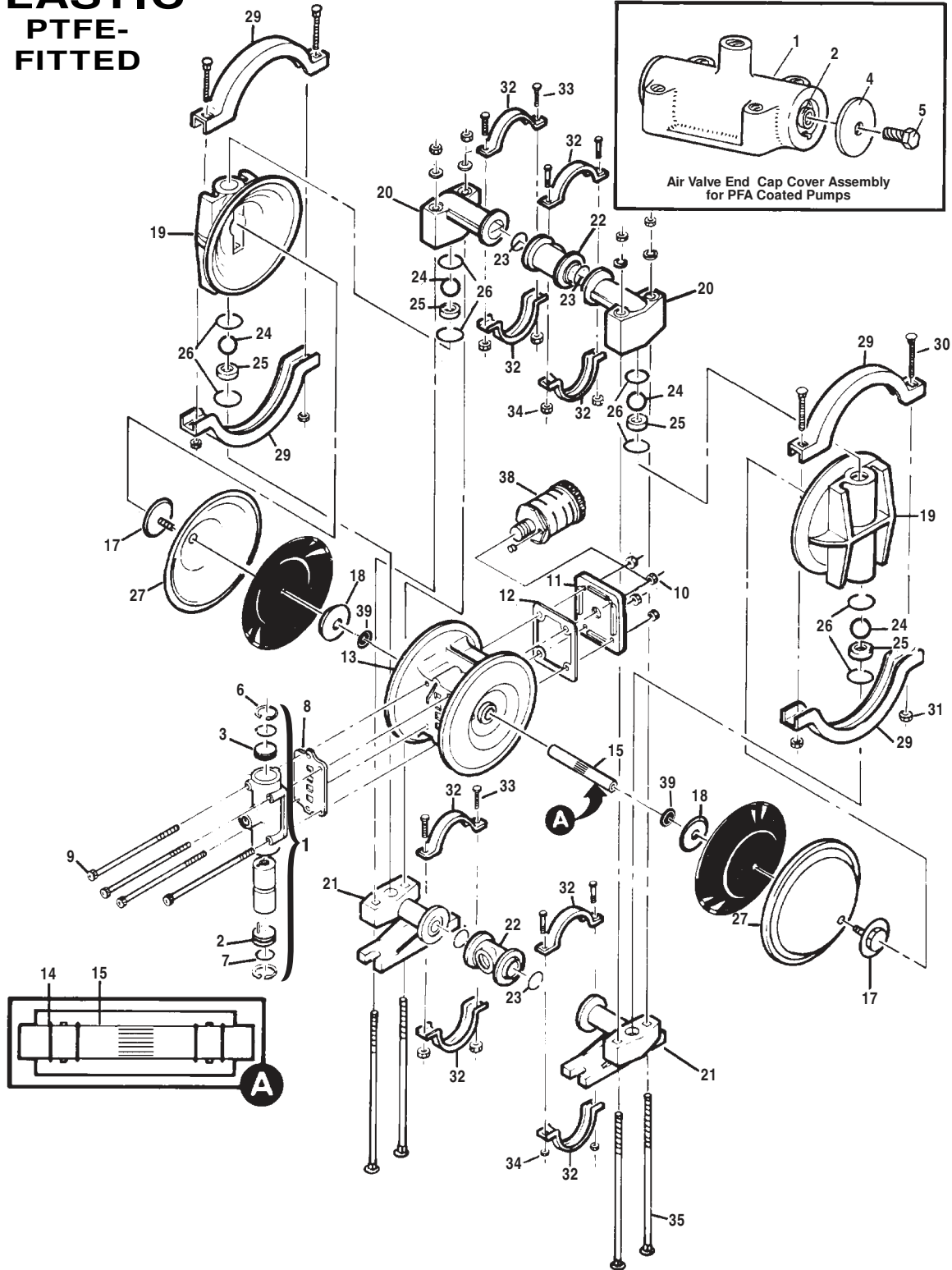

T1 PTFE-FITTED

Item	Part Description	Qty. Per Pump	T1/PPPPB P/N	T1/PPPPC/0502 P/N
1	Air Valve Assembly	1	01-2000-07	01-2000-05
2	Air Valve End Cap w/Guide (Top)	1	01-2300-23	01-2300-23
3	Air Valve End Cap w/o Guide (Bottom)	1	01-2330-23	01-2330-23
4	Air Valve End Cap Cover	2	N/A	01-2420-55
5	Air Valve End Cap Bolt	2	N/A	01-2450-22
6	Snap Ring	2	01-2650-03	01-2650-03
7	Buna-N O-Ring - 115 70 Shore	2	01-2390-52	01-2390-52
8	Air Valve Gasket	1	01-2600-52	01-2600-52
9	Air Valve Screw	4	01-6000-03	01-6000-05
10	Air Valve Screw Nut	4	04-6400-03	04-6400-05
11	Muffler Plate	1	01-3180-20	01-3180-20
12	Muffler Plate Gasket	1	01-3500-52	01-3500-52
13	Center Section	1	01-3152-20	01-3152-20
14	Center Block Glyd™ Ring	4	01-3220-55	01-3220-55
15	Shaft	1	01-3800-03-07	01-3800-03-07
16	Shaft Stud ¹	2	N/A	N/A
17	Piston, Outer	2	01-4570-20-500	01-4570-20-500
18	Piston, Inner	2	01-3710-01	01-3710-01
19	Liquid Chamber	2	01-5000-20	01-5000-20
20	Discharge Manifold Elbow	2	01-5230-20	01-5230-20
21	Inlet Manifold Elbow	2	01-5220-20	01-5220-20
22	Manifold Tee Section	2	01-5160-20	01-5160-20
23	Manifold O-Ring	4	01-1300-59-500	01-1300-59-500
24	Valve Ball	4	01-1080-55	01-1080-55
25	Valve Seats	4	01-1120-21-500	01-1120-21-500
26	Valve Seat O-Ring	8	*	*
27	Diaphragm	2	01-1010-55	01-1010-55
28	Back-up Diaphragm	2	01-1060-51	01-1060-51
29	Large Clamp Band	2	01-7300-03	01-7300-05
30	Large Clamp Band Bolt	4	01-6070-03	01-6070-05
31	Large Clamp Band Nut	4	04-6400-03	04-6400-05
32	Small Clamp Band	4	01-7100-03	01-7100-05
33	Small Clamp Band Bolt 1"	8	01-6101-03	01-6101-05
34	Small Clamp Band Nut	8	01-6400-03	01-6400-05
35	Vertical Bolt	4	01-6080-03	01-6080-05
36	Vertical Bolt Nut	4	04-6400-03	04-6400-05
37	Vertical Bolt Washer	4	01-6730-03	01-6730-05
38	Muffler	1	01-3510-99	01-3510-99
39	Disc Spring	2	01-6802-08	01-6802-08

¹Shaft stud is molded into outer piston on all plastic pumps.

*Refer to corresponding elastomer chart for correct part numbers.

0200 Specialty Code = Lube-Free

0201 Specialty Code = Lube-Free, PFA-Coated Hardware

0502 Specialty Code = PFA-Coated Hardware

0615 Specialty Code = Ultrapure w/Male Connections, Lube-Free, PFA-Coated Hardware

0625 Specialty Code = Ultrapure with Male Connections, Lube-Free

All boldface items are primary wear parts.

SECTION 10A

ELASTOMER OPTIONS

T1 Plastic Pumps

MATERIAL	Diaphragm P/N	VALVE BALL P/N	VALVE SEAT* P/N	VALVE SEAT O-RING P/N	MANIFOLD O-RING P/N
Polyurethane	01-1010-50	01-1080-50	N/A	01-1200-50	01-1300-50
Buna-N	01-1010-52	01-1080-52	N/A	00-1260-52	01-1300-52
Viton®	01-1010-53	01-1080-53	01-1120-53 ¹	N/A	01-1300-53
Wil-Flex™	01-1010-58	01-1080-58	N/A	01-1200-58	01-1300-58
Saniflex™	01-1010-56	01-1080-56	N/A	01-1200-56	01-1300-56
PTFE ²	01-1010-55	01-1080-55	01-1120-22-500	N/A	01-1300-55
PTFE ² w/intergral piston	01-1030-55	N/A	N/A	N/A	N/A
PVDF	N/A	N/A	01-1120-21-500	N/A	N/A
PTFE Encapsulated/Viton®	N/A	N/A	N/A	00-1260-60	N/A

¹Must be used with part number 01-5010-21-500.

²PTFE diaphragms require Neoprene back-up diaphragms (P/N 01-1060-51). T1 Ultrapure pump series require high-temp Buna-N back-up diaphragms (P/N 01-1060-61).

*Rubber valve seats do not require o-rings.

Elastomer Kits

Your Solutions — Wrapped Up

Program Details:

- **Elastomer & ADS Repair Kits**
- **All Sizes Available**
- **PTFE, Rubber & TPE Elastomers**
- **One Part Number Simplifies Inventory**
- **Eliminates Order Errors**
- **Reduces Re-Build Time**
- **Rejuvenates Your Pump**

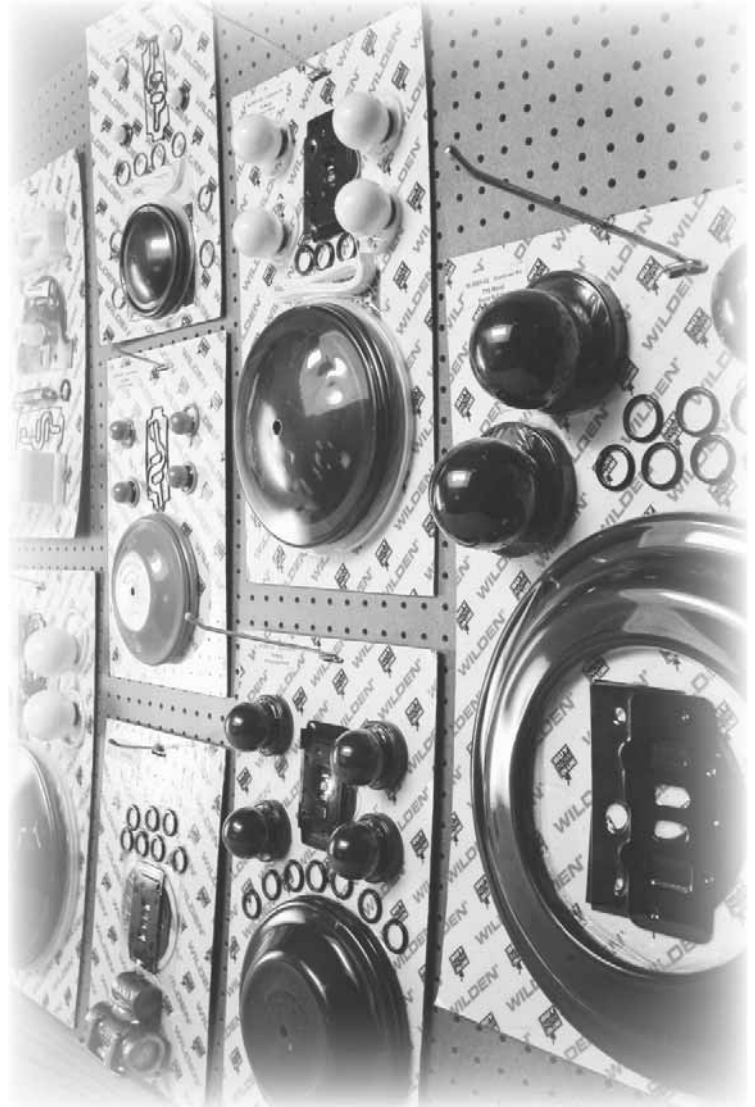

NOTE: See Section 9.

WILDEN®
A DOVER COMPANY

22069 VAN BUREN STREET • GRAND TERRACE, CA 92313-5607
(909) 422-1730 • FAX (909) 783-3440
www.wildenpump.com

WILDEN SOUND SHIELD™

Noise reduction in the workplace is critical to enhanced productivity. Realize the benefits of air-operated pump technology while providing a safe and profitable environment for your employees with Sound Shield™.

- ***Avg. 14 dBA reduction***
- ***No system modifications***
- ***Strong & light weight***
- ***Installs in minutes***

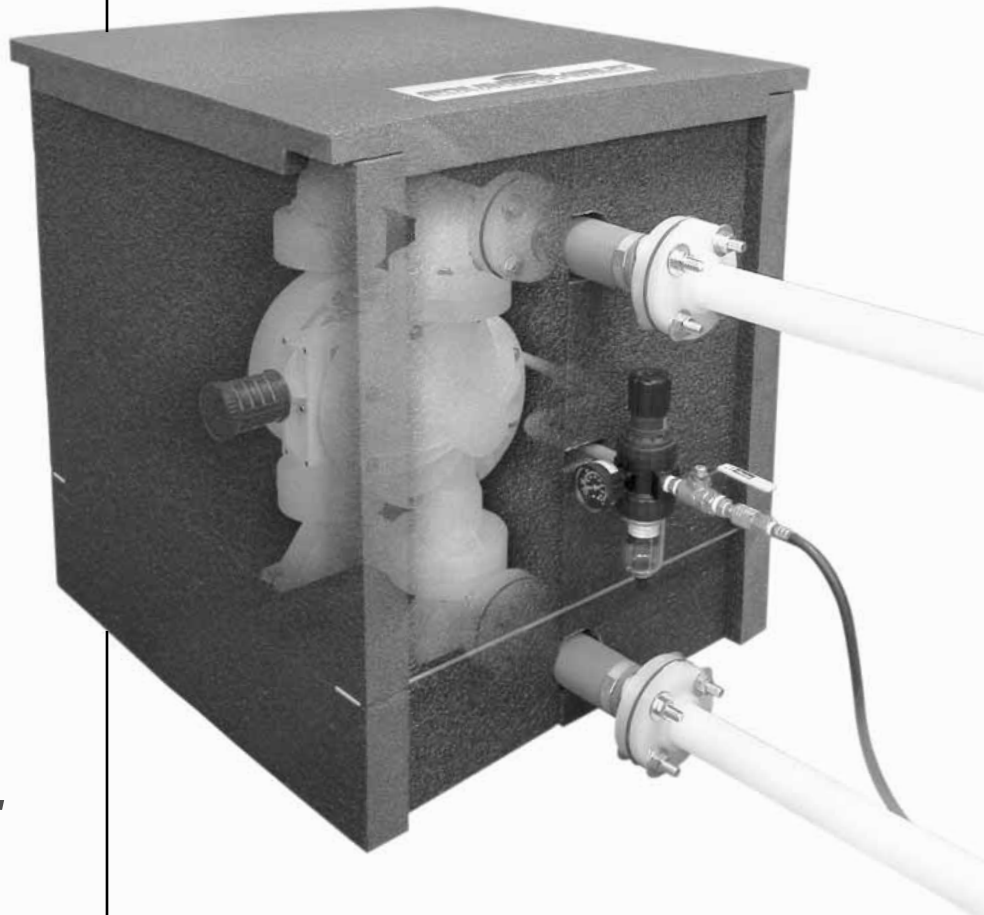

***The name
says it all.***

WILDEN®
A DOVER COMPANY

22069 VAN BUREN STREET • GRAND TERRACE, CA 92313-5607
(909) 422-1730 • FAX (909) 783-3440
www.wildenpump.com

WARRANTY

Each and every product manufactured by Wilden Pump and Engineering, LLC is built to meet the highest standards of quality. Every pump is functionally tested to insure integrity of operation.

Wilden Pump and Engineering, LLC warrants that pumps, accessories and parts manufactured or supplied by it to be free from defects in material and workmanship for a period of five (5) years from date of installation or six (6) years from date of manufacture, whichever comes first. Failure due to normal wear, misapplication, or abuse is, of course, excluded from this warranty.

Since the use of Wilden pumps and parts is beyond our control, we cannot guarantee the suitability of any pump or part for a particular application and Wilden Pump and Engineering, LLC shall not be liable for any consequential damage or expense arising from the use or misuse of its products on any application. Responsibility is limited solely to replacement or repair of defective Wilden pumps and parts.

All decisions as to the cause of failure are the sole determination of Wilden Pump and Engineering, LLC.

Prior approval must be obtained from Wilden for return of any items for warranty consideration and must be accompanied by the appropriate MSDS for the product(s) involved. A Return Goods Tag, obtained from an authorized Wilden distributor, must be included with the items which must be shipped freight prepaid.

The foregoing warranty is exclusive and in lieu of all other warranties expressed or implied (whether written or oral) including all implied warranties of merchantability and fitness for any particular purpose. No distributor or other person is authorized to assume any liability or obligation for Wilden Pump and Engineering, LLC other than expressly provided herein.

PLEASE PRINT OR TYPE AND FAX TO WILDEN

PUMP INFORMATION			
Item # _____		Serial # _____	
Company Where Purchased _____			
YOUR INFORMATION			
Company Name _____			
Industry _____			
Name _____		Title _____	
Street Address _____			
City _____	State _____	Postal Code _____	Country _____
Telephone _____	Fax _____	E-mail _____	Web Address _____
Number of pumps in facility? _____		Number of Wilden pumps? _____	
Types of pumps in facility (check all that apply): <input type="checkbox"/> Diaphragm <input type="checkbox"/> Centrifugal <input type="checkbox"/> Gear <input type="checkbox"/> Submersible <input type="checkbox"/> Lobe			
<input type="checkbox"/> Other _____			
Media being pumped? _____			
How did you hear of Wilden Pump? <input type="checkbox"/> Trade Journal <input type="checkbox"/> Trade Show <input type="checkbox"/> Internet/E-mail <input type="checkbox"/> Distributor			
<input type="checkbox"/> Other _____			

ONCE COMPLETE, FAX TO (909) 783-3440

NOTE: WARRANTY VOID IF PAGE IS NOT FAXED TO WILDEN

WILDEN PUMP & ENGINEERING, LLC