

# T2

Original™ Series **METAL** Pumps

# EOM

Engineering  
Operation &  
Maintenance

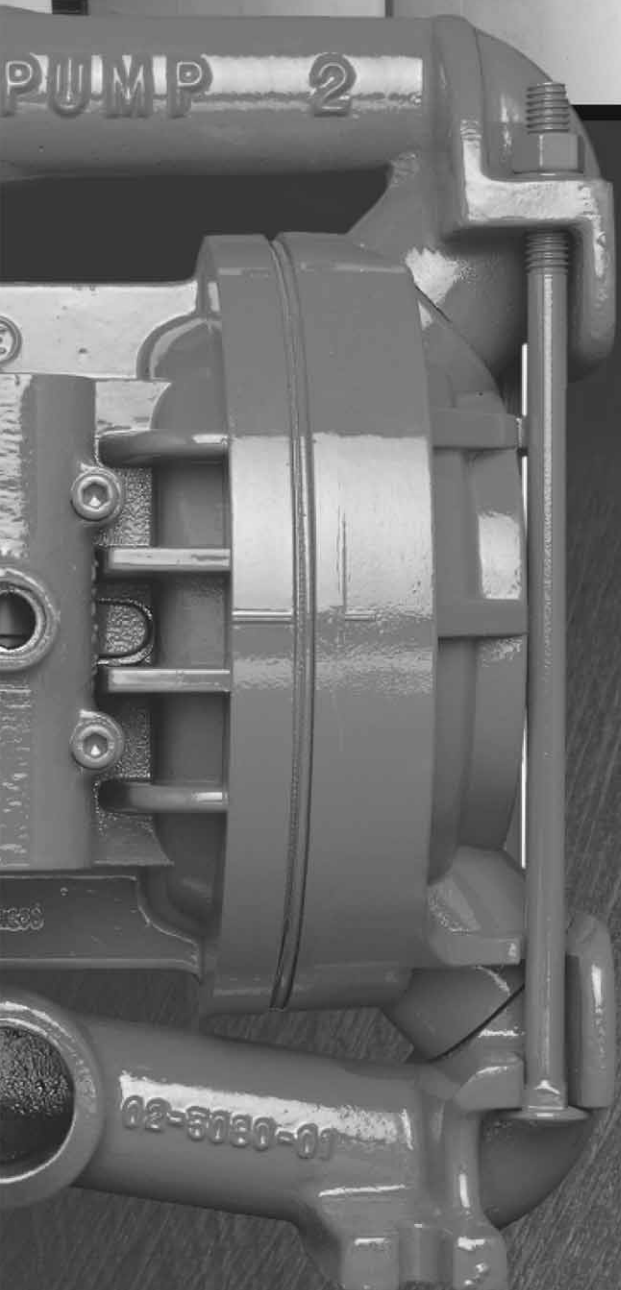

Simplify your process

**TURBO-FLO™**  
PROGRESSIVE PUMP TECHNOLOGY

**WILDEN®**  
A DOVER COMPANY



WIL-10200-E-03  
REPLACES EOM-T2M 10/03

# TABLE OF CONTENTS

	PAGE #
<b>SECTION 1 – CAUTIONS</b> .....	1
<b>SECTION 2 – PUMP DESIGNATION SYSTEM</b> .....	2
<b>SECTION 3 – HOW IT WORKS (PUMP &amp; AIR SYSTEMS)</b> .....	3
<b>SECTION 4 – DIMENSIONAL DRAWINGS</b>	
A. T2 METAL & T2 UL METAL .....	4
B. T2 METAL SANIFLO <sup>®</sup> .....	5
<b>SECTION 5 – PERFORMANCE CURVES</b>	
A. T2 METAL Rubber-Fitted.....	6
B. T2 METAL TPE-Fitted .....	6
C. T2 METAL PTFE-Fitted .....	7
<b>SECTION 6 – SUCTION LIFT CURVES &amp; DATA</b> .....	7
<b>SECTION 7 – INSTALLATION AND OPERATION</b>	
A. Installation.....	8
B. Operation & Maintenance .....	9
C. Troubleshooting Pumps.....	10
<b>SECTION 8 – DIRECTIONS FOR DISASSEMBLY/REASSEMBLY</b>	
A. T2 METAL – Disassembly, Cleaning, Inspection.....	11
B. Turbo-Flo <sup>™</sup> Pump Air Valve/Center Section – Disassembly, Cleaning, Inspection .....	13
C. Reassembly Hints & Tips.....	14
<b>SECTION 9 – EXPLODED VIEW/PARTS LISTING</b>	
A. T2 METAL Rubber/TPE-Fitted.....	16
B. T2 METAL PTFE-Fitted .....	18
<b>SECTION 10 – ELASTOMER OPTIONS</b> .....	20

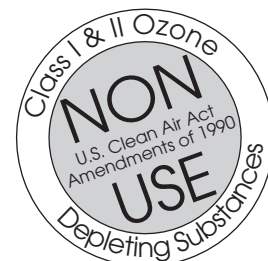

## SECTION 1

# WILDEN MODEL T2 METAL CAUTIONS – READ FIRST!



### TEMPERATURE LIMITS:

Polypropylene	0°C to 79°C	32°F to 175°F
Neoprene	-17.8°C to 93.3°C	0°F to 200°F
Buna-N	-12.2°C to 82.2°C	10°F to 180°F
EPDM	-51.1°C to 137.8°C	-60°F to 280°F
Viton®	-40°C to 176.7°C	-40°F to 350°F
Wil-Flex™	-40°C to 107.2°C	-40°F to 225°F
Polyurethane	-12.2°C to 65.6°C	10°F to 150°F
Saniflex™	-28.9°C to 104.4°C	-20°F to 220°F
PTFE	4.4°C to 148.9°C	40°F to 300°F



**CAUTION:** When choosing pump materials, be sure to check the temperature limits for all wetted components. Example: Viton® has a maximum limit of 176.7°C (350°F) but polypropylene has a maximum limit of only 79°C (175°F).



**CAUTION:** Maximum temperature limits are based upon mechanical stress only. Certain chemicals will significantly reduce maximum safe operating temperatures. Consult engineering guide for chemical compatibility and temperature limits.



**CAUTION:** Always wear safety glasses when operating pump. If diaphragm rupture occurs, material being pumped may be forced out air exhaust.



**WARNING:** Prevention of static sparking — If static sparking occurs, fire or explosion could result. Pump, valves, and containers must be properly grounded when handling flammable fluids and whenever discharge of static electricity is a hazard.



**CAUTION:** Do not exceed 8.6 bar (125 psig) air supply pressure. (3.4 bar [50 psig] for UL models.)



**CAUTION:** Before any maintenance or repair is attempted, the compressed air line to the pump should be disconnected and all air pressure allowed to bleed from pump. Disconnect all intake, discharge and air lines. Drain the pump by turning it upside down and allowing any fluid to flow into a suitable container.



**CAUTION:** Blow out air line for 10 to 20 seconds before attaching to pump to make sure all pipe line debris is clear. Use an in-line air filter. A 5µ (micron) air filter is recommended.



**NOTE:** Tighten clamp bands and retainers prior to installation. Fittings may loosen during transportation.



**NOTE:** When installing PTFE diaphragms, it is important to tighten outer pistons simultaneously (turning in opposite directions) to ensure tight fit.



**NOTE:** Before starting disassembly, mark a line from each liquid chamber to its corresponding air chamber. This line will assist in proper alignment during reassembly.



**CAUTION:** Verify the chemical compatibility of the process and cleaning fluid to the pump's component materials in the Chemical Resistance Guide.



**CAUTION:** When removing the end cap using compressed air, the air valve end cap may come out with considerable force. Hand protection such as a padded glove or rag should be used to capture the end cap.



**CAUTION:** Only explosion proof (NEMA 7) solenoid valves should be used in areas where explosion proof equipment is required.



**NOTE:** All non lube-free air-operated pumps must be lubricated. Wilden suggests an arctic 5 weight oil (ISO grade 15). Do not over-lubricate pump. Over-lubrication will reduce pump performance.



**NOTE:** UL-listed pumps must not exceed 3.4 bar (50 psig) air supply pressure.



**CAUTION:** Do not lubricate lube-free pumps.



**CAUTION:** For UL listed pumps, do not exceed 3.4 bar (50 psig) air supply pressure.



**CAUTION:** For UL listed pumps, all pipe connections are to be made using UL Classified gasoline-resistant pipe compound.



**CAUTION:** For UL listed pumps, all installations must conform with NFPA 30, NFPA 30A, and all other applicable codes.



**CAUTION:** For UL listed pumps, air exhaust port is to be connected to pipe or tubing to be routed outdoors or other location determined to be equivalent.



**CAUTION:** For UL listed pumps, pump is to be grounded using the jam-nut located atop the long vertical carriage bolt. The ground connection is marked with a tag having the grounding symbol.



Grounding Symbol

## SECTION 2

# WILDEN PUMP DESIGNATION SYSTEM

## T2 ORIGINAL™ METAL

### LEGEND

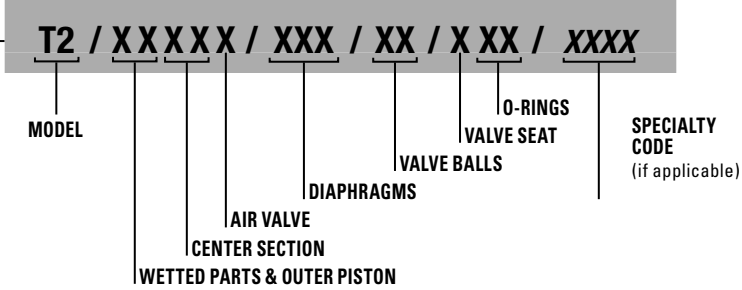

## MODEL T2 METAL MATERIAL CODES

### WETTED PARTS & OUTER PISTON

AA = ALUMINUM / ALUMINUM  
 AZ = ALUMINUM / NO PISTON  
 SS = STAINLESS STEEL /  
 STAINLESS STEEL  
 SZ = STAINLESS STEEL /  
 NO PISTON

### CENTER SECTION

AA = ALUMINUM  
 CC = PFA COATED ALUMINUM  
 NN = NICKEL PLATED ALUMINUM  
 PP = POLYPROPYLENE

### AIR VALVE

B = BRASS  
 C = PTFE PFA COATED  
 N = NICKEL PLATED  
 \* = NO AIR VALVE

### DIAPHRAGMS

BNS = BUNA-N (Red Dot)  
 EPS = EPDM (Blue Dot)  
 FSS = SANIFLEX™  
 [Hytrel® (Cream)]  
 LEL = PTFE-EPDM BACKED, IPD  
 NES = NEOPRENE (Green Dot)  
 PUS = POLYURETHANE (Clear)  
 TEU = PTFE W/EPDM  
 BACK-UP (White)  
 TNU = PTFE W/NEOPRENE  
 BACK-UP (White)  
 TSU = PTFE W/SANIFLEX™  
 BACK-UP (White)  
 VTS = VITON® (White Dot)  
 WFS = WIL-FLEX™ [Santoprene®  
 (Orange Dot)]  
 XBS = CONDUCTIVE BUNA-N  
 (Two Red Dots)

### VALVE BALL

BN = BUNA-N (Red Dot)  
 EP = EPDM (Blue Dot)  
 FS = SANIFLEX™  
 [Hytrel® (Cream)]  
 FV = SANITARY VITON®  
 (Two White Dots)  
 NE = NEOPRENE (Green Dot)  
 PU = POLYURETHANE (Brown)  
 TF = PTFE (White)  
 VT = VITON® (White Dot)  
 WF = WIL-FLEX™ [Santoprene®  
 (Orange Dot)]

### VALVE SEAT

A = ALUMINUM  
 S = STAINLESS STEEL

### VALVE SEAT O-RING

BN = BUNA-N  
 EP = EPDM  
 FS = SANIFLEX™  
 [Hytrel® (Cream)]  
 PU = POLYURETHANE (Brown)  
 TF = PTFE (White)  
 WF = WIL-FLEX™ [Santoprene®]

## SPECIALTY CODES

0002 Unpainted, special instructions  
 0014 BSPT  
 0017 BSPT, unpainted, special instructions  
 0023 Wing nuts  
 0070 Saniflo™ FDA  
 0079 Tri-clamp fittings, wing nuts  
 0080 Tri-clamp fittings ONLY  
 0090 UL listed  
 0091 UL listed, Wil-Gard II™ 110V  
 0100 Wil-Gard II™ 110V  
 0102 Wil-Gard II™ sensor wires ONLY  
 0103 Wil-Gard II™ 220V  
 0104 Wil-Gard II™ 110V, spark free

0105 Spark free, Wil-Gard II™ 220V  
 0108 BSPT, Wil-Gard II™ 220V  
 0120 Saniflo™ FDA, Wil-Gard II™ 110V  
 0206 PFA coated hardware,  
 Wil-Gard II™ sensor wires ONLY  
 0247 Discharge and inlet facing exhaust, special  
 instructions  
 0249 Discharge facing forward, spark free,  
 BSPT, special instructions  
 0250 Discharge facing forward, special  
 instructions  
 0251 Discharge facing forward, BSPT,  
 special instructions

0300 Without air valve  
 0315 PFA coated hardware, BSPT  
 0330 Wing nuts, BSPT  
 0502 PFA coated hardware  
 0603 PFA coated hardware, Wil-Gard II™ 110V  
 0608 PFA coated hardware, Wil-Gard II™ 220V

**NOTE: MOST ELASTOMERIC MATERIALS USE COLORED DOTS FOR IDENTIFICATION.**

Viton is a registered trademark of DuPont Dow Elastomers.

## SECTION 3

# THE WILDEN PUMP – HOW IT WORKS

The Wilden diaphragm pump is an air-operated, positive displacement, self-priming pump. These drawings show the flow pattern through the pump upon its initial stroke. It is assumed the pump has no fluid in it prior to its initial stroke.

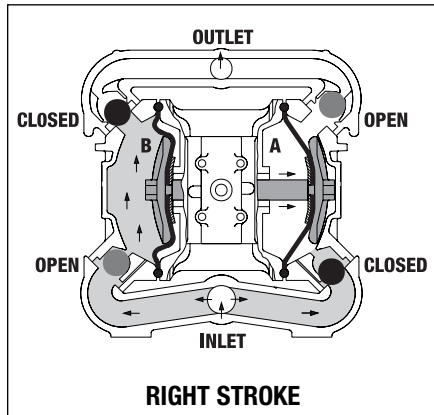

**RIGHT STROKE**

FIGURE 1 The air valve directs pressurized air to the back side of diaphragm A. The compressed air is applied directly to the liquid column separated by elastomeric diaphragms. The diaphragm acts as a separation membrane between the compressed air and liquid, balancing the load and removing mechanical stress from the diaphragm. The compressed air moves the diaphragm away from the center block of the pump. The opposite diaphragm is pulled in by the shaft connected to the pressurized diaphragm. Diaphragm B is on its suction stroke; air behind the diaphragm has been forced out to the atmosphere through the exhaust port of the pump. The movement of diaphragm B toward the center block of the pump creates a vacuum within chamber B. Atmospheric pressure forces fluid into the inlet manifold forcing the inlet valve ball off its seat. Liquid is free to move past the inlet valve ball and fill the liquid chamber (see shaded area).

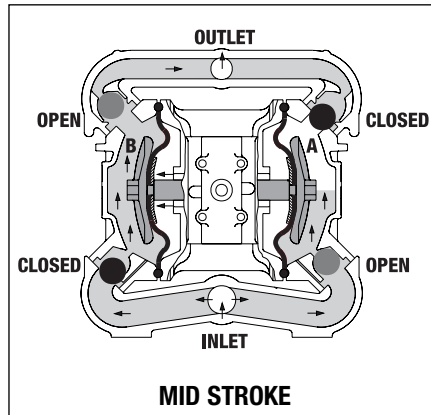

**MID STROKE**

FIGURE 2 When the pressurized diaphragm, diaphragm A, reaches the limit of its discharge stroke, the air valve redirects pressurized air to the back side of diaphragm B. The pressurized air forces diaphragm B away from the center block while pulling diaphragm A to the center block. Diaphragm B is now on its discharge stroke. Diaphragm B forces the inlet valve ball onto its seat due to the hydraulic forces developed in the liquid chamber and manifold of the pump. These same hydraulic forces lift the discharge valve ball off its seat, while the opposite discharge valve ball is forced onto its seat, forcing fluid to flow through the pump discharge. The movement of diaphragm A toward the center block of the pump creates a vacuum within liquid chamber A. Atmospheric pressure forces fluid into the inlet manifold of the pump. The inlet valve ball is forced off its seat allowing the fluid being pumped to fill the liquid chamber.

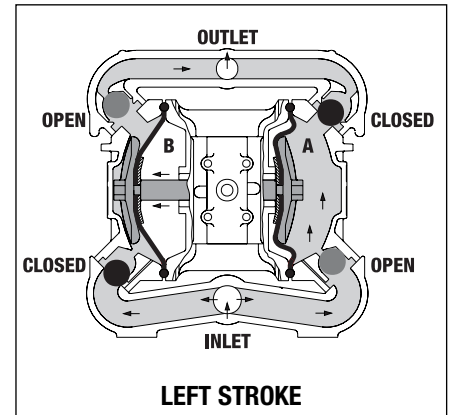

**LEFT STROKE**

FIGURE 3 At completion of the stroke, the air valve again redirects air to the back side of diaphragm A, which starts diaphragm B on its exhaust stroke. As the pump reaches its original starting point, each diaphragm has gone through one exhaust and one discharge stroke. This constitutes one complete pumping cycle. The pump may take several cycles to completely prime depending on the conditions of the application.

## SECTION 4A

# DIMENSIONAL DRAWING T2 METAL

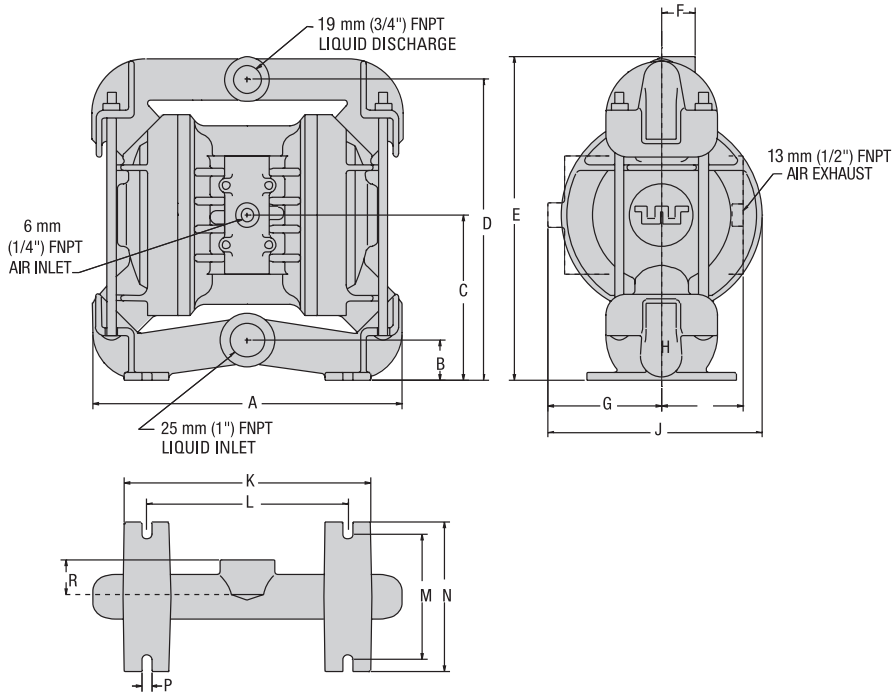

### DIMENSIONS

ITEM	METRIC (mm)	STANDARD (inch)
A	267	10.5
B	36	1.4
C	137	5.4
D	254	10.0
E	279	11.0
F	28	1.1
G	97	3.8
H	76	3.0
J	185	7.3
K	211	8.3
L	173	6.8
M	107	4.2
N	127	5.0
P	8	0.3
R	33	1.3

BSPT Threads available

## T2 METAL - UL LISTED

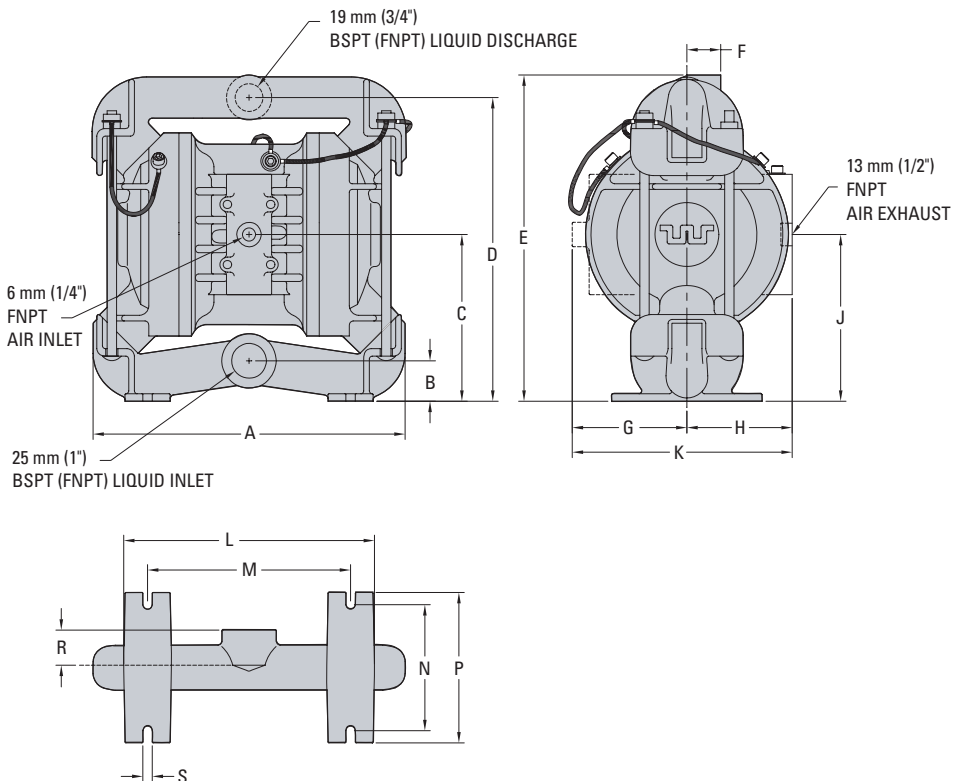

### DIMENSIONS

ITEM	METRIC (mm)	STANDARD (inch)
A	267	10.5
B	36	1.4
C	137	5.4
D	254	10.0
E	279	11.0
F	28	1.1
G	97	3.8
H	89	3.5
J	137	5.4
K	198	7.8
L	211	8.3
M	173	6.8
N	107	4.2
P	127	5.0
R	33	1.3
S	8	0.3

# SECTION 4B

# DIMENSIONAL DRAWING

# T2 METAL SANIFLO<sup>FDA</sup>

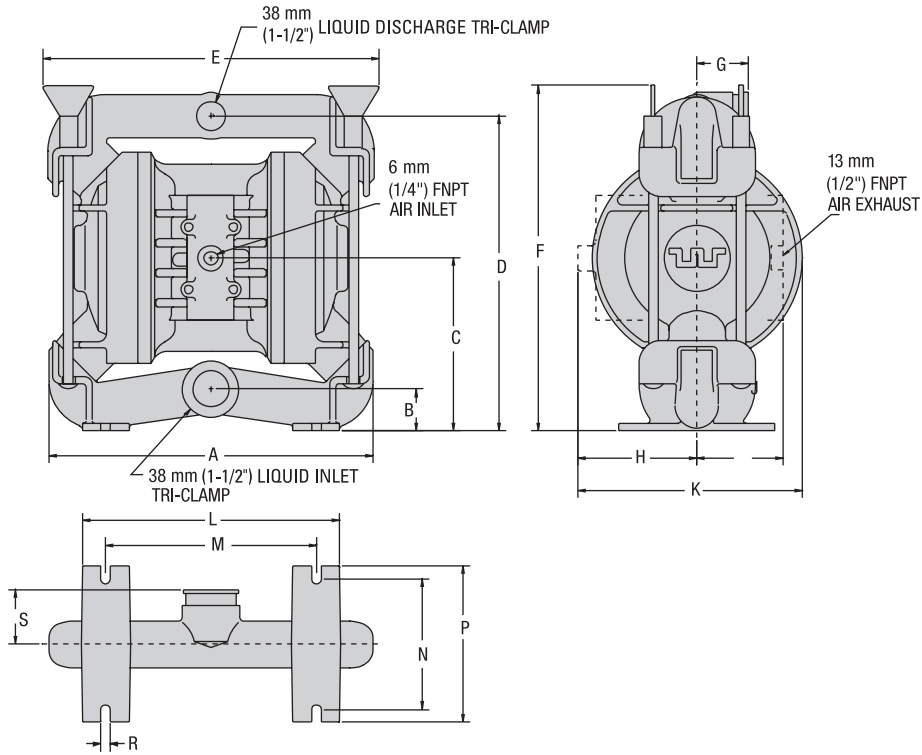

## DIMENSIONS

ITEM	METRIC (mm)	STANDARD (inch)
A	264	10.4
B	36	1.4
C	137	5.4
D	257	10.1
E	267	10.5
F	295	11.6
G	41	1.6
H	97	3.8
J	74	2.9
K	183	7.2
L	211	8.3
M	173	6.8
N	107	4.2
P	127	5.0
R	8	0.3
S	43	1.7

## SECTION 5A

# PERFORMANCE CURVES T2 METAL RUBBER-FITTED

Height..... 279 mm (11.0")  
 Width..... 267 mm (10.5")  
 Depth..... 185 mm (7.3")  
 Est. Ship Weight..... Aluminum 12 kg (26 lbs)  
                                   Stainless Steel 16 kg (36 lbs)  
 Air Inlet..... 6 mm (1/4")  
 Inlet..... 25 mm (1")  
 Outlet..... 19 mm (3/4")  
 Suction Lift..... 5.18 m Dry (17')  
                                   9.45 m Wet (31')

Displacement per  
 Stroke..... 0.41 l (0.105 gal.)<sup>1</sup>  
 Max. Flow Rate..... 132 lpm (35 gpm)  
 Max. Size Solids..... 3.2 mm (1/8")

<sup>1</sup>Displacement per stroke was calculated at 4.8 bar (70 psig) air inlet pressure against a 2 bar (30 psig) head pressure.

**Example:** To pump 68.1 lpm (18.0 gpm) against a discharge pressure head of 2.7 bar (40 psig) requires 4.1 bar (60 psig) and 18.7 Nm<sup>3</sup>/h (11 scfm) air consumption. (See dot on chart.)

**Caution: Do not exceed 8.6 bar (125 psig) air supply pressure.**

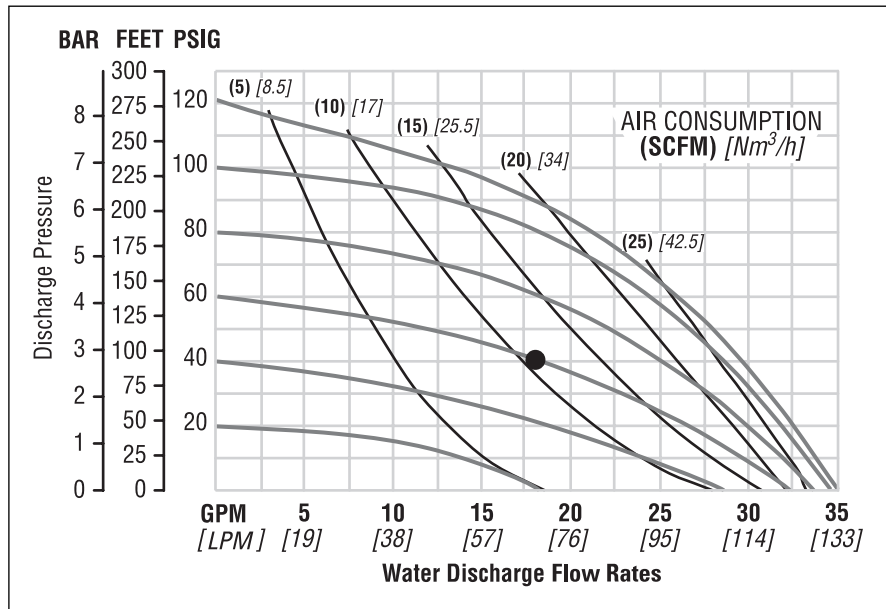

Flow rates indicated on chart were determined by pumping water.

For optimum life and performance, pumps should be specified so that daily operation parameters will fall in the center of the pump performance curve.

## SECTION 5B

# PERFORMANCE CURVES T2 METAL TPE-FITTED

Height..... 279 mm (11.0")  
 Width..... 267 mm (10.5")  
 Depth..... 185 mm (7.3")  
 Est. Ship Weight..... Aluminum 12 kg (26 lbs)  
                                   Stainless Steel 16 kg (36 lbs)  
 Air Inlet..... 6 mm (1/4")  
 Inlet..... 25 mm (1")  
 Outlet..... 19 mm (3/4")  
 Suction Lift..... 1.52 m Dry (5')  
                                   9.45 m Wet (31')

Displacement per  
 Stroke..... 0.41 l (0.105 gal.)<sup>1</sup>  
 Max. Flow Rate..... 132 lpm (35 gpm)  
 Max. Size Solids..... 3.2 mm (1/8")

<sup>1</sup>Displacement per stroke was calculated at 4.8 bar (70 psig) air inlet pressure against a 2 bar (30 psig) head pressure.

**Example:** To pump 60.6 lpm (16.0 gpm) against a discharge pressure head of 2.7 bar (40 psig) requires 4 bar (60 psig) and 17 Nm<sup>3</sup>/h (10 scfm) air consumption. (See dot on chart.)

**Caution: Do not exceed 8.6 bar (125 psig) air supply pressure.**

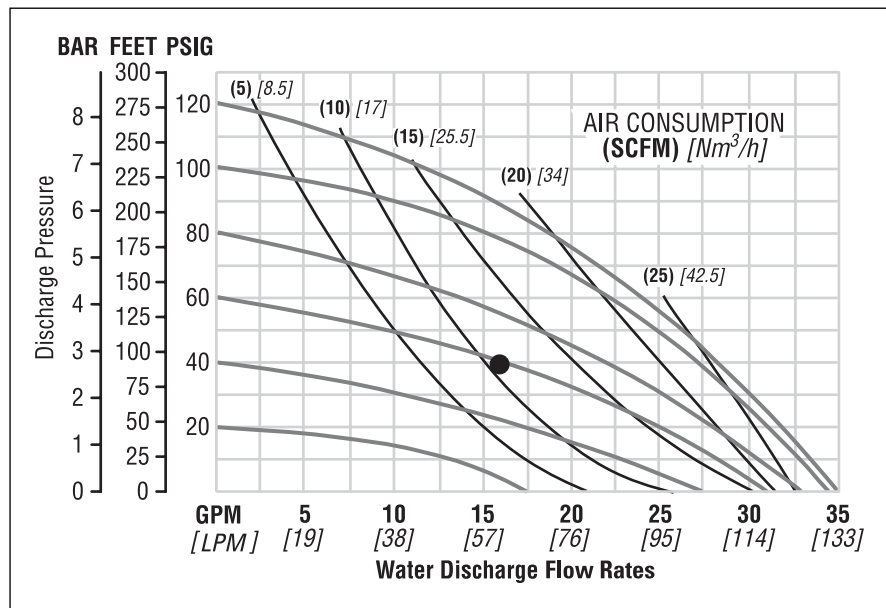

Flow rates indicated on chart were determined by pumping water.

For optimum life and performance, pumps should be specified so that daily operation parameters will fall in the center of the pump performance curve.





# SECTION 7A

## INSTALLATION

---

The Model T2 Metal pump has a 25 mm (1") inlet and 19 mm (3/4") outlet and is designed for flows to 132 lpm (35 gpm). The T2 Metal pump is manufactured with wetted parts of aluminum or stainless steel. The center section of the T2 Metal pump is of aluminum or polypropylene construction. The air distribution system consists of a brass air valve body, aluminum air valve piston, Glyd™ rings and a bronze center section bushing. A variety of diaphragms, valve balls, valve seats, and o-rings are available to satisfy temperature, chemical compatibility, abrasion and flex concerns.

The suction pipe size should be at least 25 mm (1") diameter or larger if highly viscous material is being pumped. The suction hose must be non-collapsible, reinforced type as the T2 is capable of pulling a high vacuum. Discharge piping should be at least 19 mm (3/4"); larger diameter can be used to reduce friction losses. It is critical that all fittings and connections are airtight or a reduction or loss of pump suction capability will result.

**INSTALLATION:** Months of careful planning, study, and selection efforts can result in unsatisfactory pump performance if installation details are left to chance.

Premature failure and long term dissatisfaction can be avoided if reasonable care is exercised throughout the installation process.

**LOCATION:** Noise, safety, and other logistical factors usually dictate that "utility" equipment be situated away from the production floor. Multiple installations with conflicting requirements can result in congestion of utility areas, leaving few choices for siting of additional pumps.

Within the framework of these and other existing conditions, every pump should be located in such a way that four key factors are balanced against each other to maximum advantage.

1. **ACCESS:** First of all, the location should be accessible. If it's easy to reach the pump, maintenance personnel will have an easier time carrying out routine inspections and adjustments. Should major repairs become necessary, ease of access can play a key role in speeding the repair process and reducing total downtime.

2. **AIR SUPPLY:** Every pump location should have an air line large enough to supply the volume of air necessary to achieve the desired pumping rate (see pump performance chart). Use air pressure up to a maximum of 8.6 bar (125 psig) depending upon pumping requirements. The use of an air filter before the pump will ensure that the majority of any pipeline contaminants will be eliminated. For best results, the pumps should use an air filter, regulator, and lubricator system.

3. **ELEVATION:** Selecting a site that is well within the pump's suction lift capability will assure that loss-of-prime troubles will be eliminated. In addition, pump efficiency can be adversely affected if proper attention is not given to elevation (see pump performance chart).

4. **PIPING:** Final determination of the pump site should not be made until the piping problems of each possible location have been evaluated. The impact of current and future installations should be considered ahead of time to make sure that inadvertent restrictions are not created for any remaining sites.

For UL listed pumps, all installations must conform with NFPA 30, NFPA 30A, and all other applicable codes. All pipe connections are to be made using UL Classified gasoline-resistant pipe compound. Exhaust port is to be connected to pipe or tubing to be routed outdoors or other location determined to be equivalent

The best choice possible will be a site involving the shortest and the straightest hook-up of suction and discharge piping. Unnecessary elbows, bends, and fittings should be avoided. Pipe sizes should be selected so as to keep friction losses within practical limits. All piping should be supported independently of the pump. In addition, it should line up without placing stress on the pump fittings.

Expansion joints can be installed to aid in absorbing the forces created by the natural reciprocating action of the pump. If the pump is to be bolted down to a solid foundation, a mounting pad placed between the pump and foundation will assist in minimizing pump vibration. Flexible connections between the pump and rigid piping will also assist in minimizing pump vibration. If quick-closing valves are installed at any point in the discharge system, or if pulsation within a system becomes a problem, a surge suppressor should be installed to protect the pump, piping and gauges from surges and water hammer.

When pumps are installed in applications involving flooded suction or suction head pressures, a gate valve should be installed in the suction line to permit closing of the line for pump service.

The T2 can be used in submersible applications only when both wetted and non-wetted portions are compatible with the material being pumped. If the pump is to be used in a submersible application, a hose should be attached to the pump's air exhaust and the exhaust air piped above the liquid level.

If the pump is to be used in a self-priming application, be sure that all connections are airtight and that the suction lift is within the pump's ability. Note: Materials of construction and elastomer material have an effect on suction lift parameters. Please refer to pump performance data.

Pumps in service with a positive suction head are most efficient when inlet pressure is limited to 0.5–0.7 bar (7–10 psig). Premature diaphragm failure may occur if positive suction is 0.8 bar (11 psig) and higher.

**THE MODEL T2 WILL PASS 3.2 mm (1/8") SOLIDS. WHENEVER THE POSSIBILITY EXISTS THAT LARGER SOLID OBJECTS MAY BE SUCKED INTO THE PUMP, A STRAINER SHOULD BE USED ON THE SUCTION LINE.**

**CAUTION: DO NOT EXCEED 8.6 BAR (125 PSIG) AIR SUPPLY PRESSURE. (3.4 BAR [50 PSIG] FOR UL MODELS.)**

**BLOW OUT AIR LINE FOR 10 TO 20 SECONDS BEFORE ATTACHING TO PUMP TO MAKE SURE ALL PIPE LINE DEBRIS IS CLEAR. ALWAYS USE AN IN-LINE AIR FILTER.**

# SUGGESTED INSTALLATION

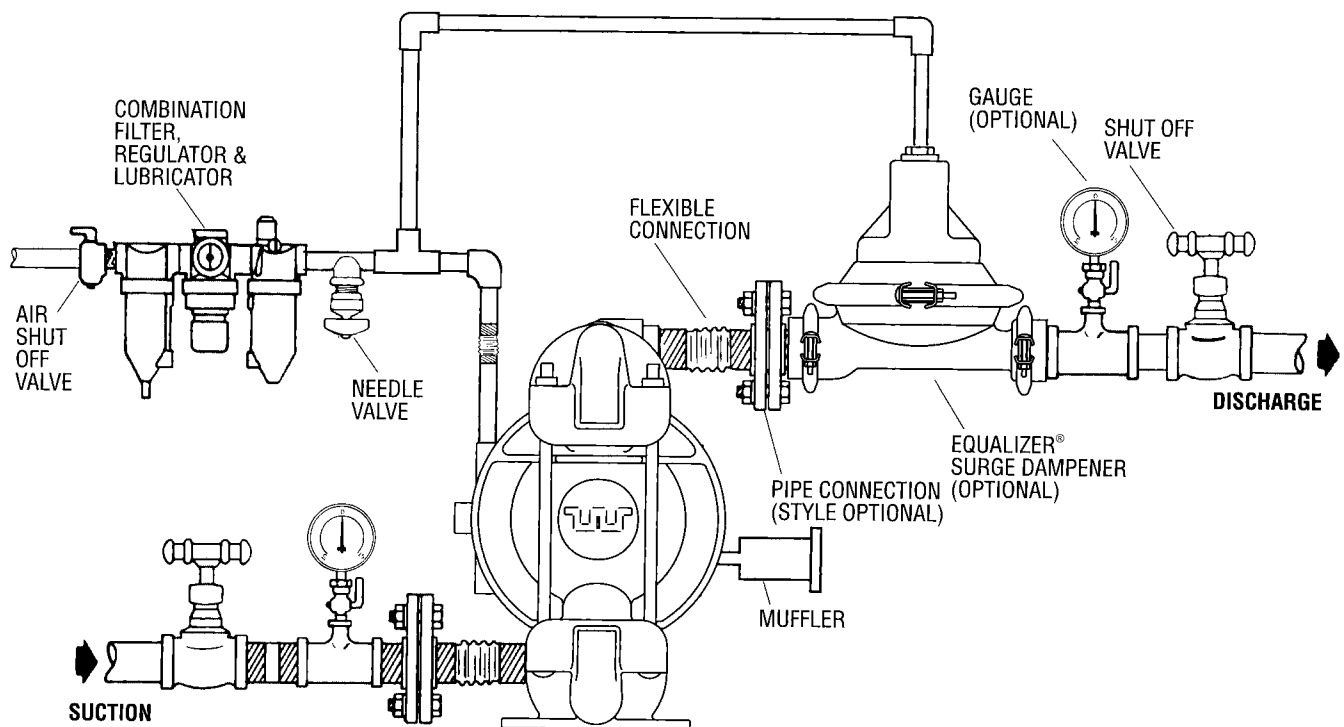

**NOTE:** In the event of a power failure, the shutoff valve should be closed, if the restarting of the pump is not desirable once power is regained.

**AIR OPERATED PUMPS:** To stop the pump from operating in an emergency situation, simply close the "shut-off" valve (user supplied) installed in the air supply line. A properly functioning valve will stop the air supply to the pump, therefore stopping output. This shut-off valve should be located far enough away from the pumping equipment such that it can be reached safely in an emergency situation.

## SECTION 7B

# SUGGESTED OPERATION AND MAINTENANCE INSTRUCTIONS

**OPERATION:** Pump discharge rate can be controlled by limiting the volume and/or pressure of the air supply to the pump (preferred method). An air regulator is used to regulate air pressure. A needle valve is used to regulate volume. Pump discharge rate can also be controlled by throttling the pump discharge by partially closing a valve in the discharge line of the pump. This action increases friction loss which reduces flow rate. This is useful when the need exists to control the pump from a remote location. When the pump discharge pressure equals or exceeds the air supply pressure, the pump will stop; no bypass or pressure relief valve is needed, and pump damage will not occur. The pump has reached a "deadhead" situation and can be restarted by reducing the fluid discharge pressure or increasing the air inlet pressure. The Wilden T2 pump runs solely on compressed air and does not generate heat, therefore your process fluid temperature will not be affected.

**RECORDS:** When service is required, a record should be made of all necessary repairs and replacements. Over a period of time, such records can become a valuable tool for predicting and preventing future maintenance problems and unscheduled downtime. In addition, accurate records make it possible to identify pumps that are poorly suited to their applications.

**MAINTENANCE AND INSPECTIONS:** Since each application is unique, maintenance schedules may be different for every pump. Frequency of use, line pressure, viscosity and abrasiveness of process fluid all affect the parts life of a Wilden pump. Periodic inspections have been found to offer the best means for preventing unscheduled pump downtime. Personnel familiar with the pump's construction and service should be informed of any abnormalities that are detected during operation.

# **SECTION 7C – AIR OPERATION**

---

## **TROUBLESHOOTING**

---

### ***Pump will not run or runs slowly.***

1. Check air inlet screen and air filter for debris.
2. Check for sticking air valve, flush air valve in solvent.
3. Check for worn out air valve. If piston face in air valve is shiny instead of dull, air valve is probably worn beyond working tolerances and must be replaced.
4. Check center block Glyd™ rings. If worn excessively, they will not seal and air will simply flow through pump and out air exhaust. Use only Wilden Glyd™ rings as they are of special construction.
5. Check for rotating piston in air valve.
6. Check type of lubricant being used. A higher viscosity oil than suggested may cause the piston to stick or run erratically. Wilden suggests the use of an oil with arctic characteristics (ISO 15-5 wt.).

### ***Pump runs but little or no product flows.***

1. Check for pump cavitation; slow pump speed down to match thickness of material being pumped.

2. Check for sticking ball check valves. If material being pumped is not compatible with pump elastomers, swelling may occur. Replace ball check valves and o-rings with the proper elastomers.
3. Check to make sure all suction connections are air tight, especially clamp bands around intake balls.

### ***Pump air valve freezes.***

Check for excessive moisture in compressed air. Either install dryer or hot air generator for compressed air.

### ***Air bubbles in pump discharge.***

1. Check for ruptured diaphragm.
2. Check tightness of clamp bands, especially at intake manifold.

### ***Product comes out air exhaust.***

1. Check for diaphragm rupture.
2. Check tightness of piston plates to shaft.

## SECTION 8A

# T2 METAL

## DIRECTIONS FOR DISASSEMBLY/REASSEMBLY

**CAUTION:** Before any maintenance or repair is attempted, the compressed air line to the pump should be disconnected and all air pressure allowed to bleed from the pump. Disconnect all intake, discharge, and air lines. Drain the pump by turning it upside down and allowing any fluid to flow into a suitable container. Be aware of any hazardous effects of contact with your process fluid.

The Wilden model T2 has a 25 mm (1") inlet and 19 mm (3/4") outlet and is designed for flows up to 132 lpm (35 gpm). The single-piece center section, consisting of center block and air chambers, is molded of polypropylene or aluminum. The air valve is manufactured of brass or high-tech, engineered thermoplastics. All o-rings used in the pump are of a special material and shore hardness that should only be replaced with factory-supplied parts.

### TOOLS REQUIRED:

Adjustable Wrench

9/16" Box Wrench

3/4" Box Wrench

Vise equipped with soft jaws (such as plywood, plastic or other suitable material)

**NOTE:** The model used for these instructions incorporates rubber diaphragms, balls, and seats. Models with PTFE diaphragms, balls and seats are the same except where noted.

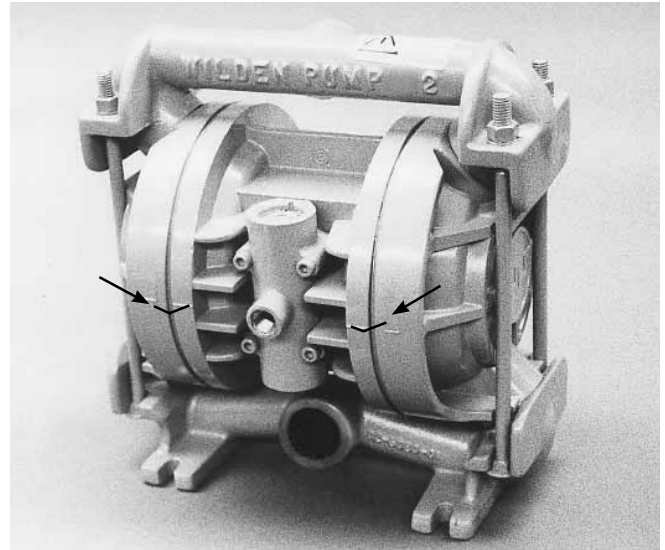

### DISASSEMBLY:

Figure 1

#### Step 1.

Before starting disassembly, mark a line from each liquid chamber to its corresponding air chamber. This line will assist in proper alignment during reassembly.

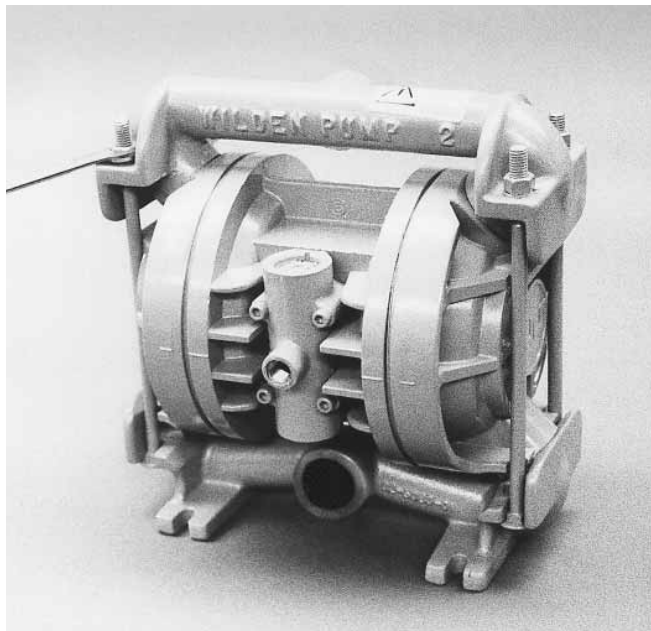

#### Step 2.

Figure 2

Utilizing the 9/16" box wrench, start by removing the four long carriage bolts that secure the top and bottom manifolds to the center section.

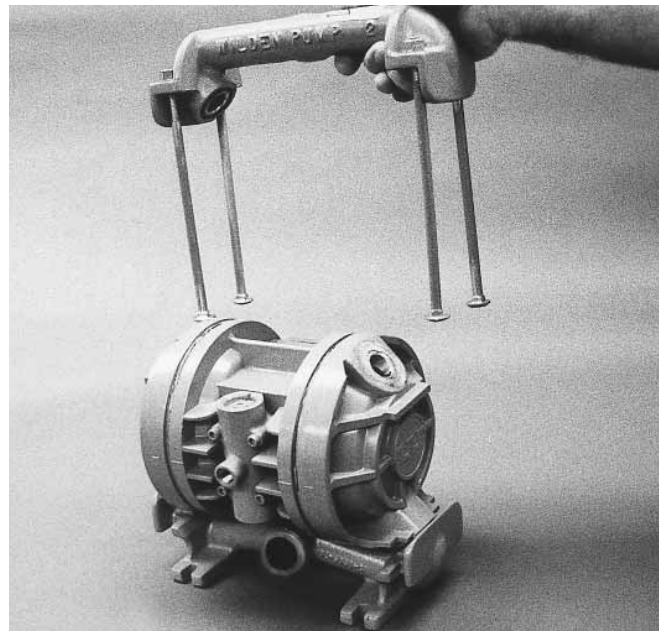

#### Step 3.

Figure 3

Remove the top manifold and lift the center section off the inlet manifold.

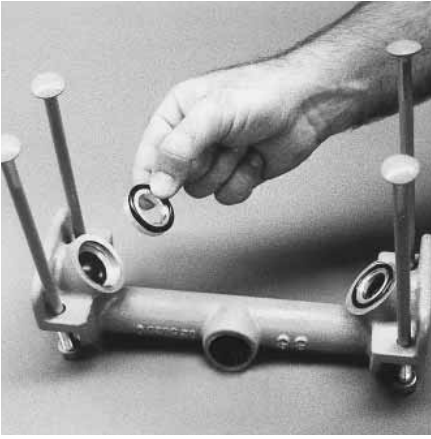

**Step 4.** *Figure 4*

Remove the discharge valve balls, seats and o-rings from the discharge manifold and inspect for nicks, gouges, chemical attack or abrasive wear. Replace worn parts with genuine Wilden parts for reliable performance. PTFE o-rings should be replaced when reassembled.



**Step 5.** *Figure 5*

Inspect the valve seat, valve seat o-ring, and valve ball from intake manifold. Check for nicks, gouges, chemical attack or abrasive wear. Replace worn parts with genuine Wilden parts for reliable performance. PTFE o-rings should be replaced when reassembled.



**Step 6.** *Figure 6*

With the 3/4" box wrench or by rotating the diaphragm by hand, remove the diaphragm assembly.



**Step 7.** *Figure 7*

**NOTE:** Due to varying torque values, one of the following two situations may occur: 1) The outer piston, diaphragm and inner piston remain attached to the shaft and the entire assembly can be removed from the center section.

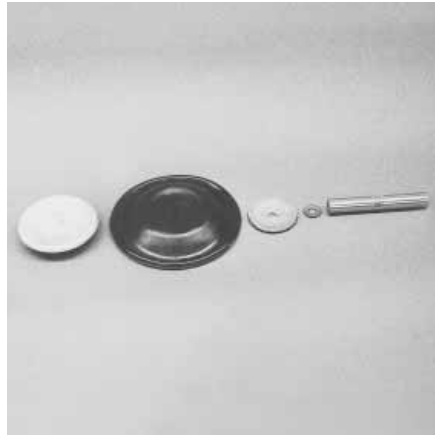

**Step 8.** *Figure 8*

2) The outer piston, diaphragm, inner piston, and disc spring separate from the shaft which remains connected to the opposite side diaphragm assembly (*Figure 8*). PTFE-fitted pumps come standard with back-up diaphragms (not shown).

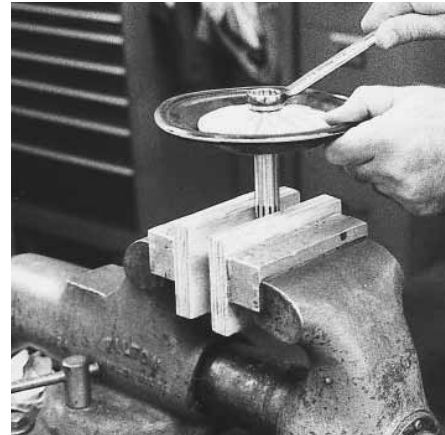

**Step 9.** *Figure 9*

To remove the diaphragm assembly from the shaft, secure shaft with soft jaws (a vise fitted with plywood or other suitable material) to ensure shaft is not nicked, scratched, or gouged. Using an adjustable wrench, remove diaphragm assembly from shaft. Inspect all parts for wear and replace with genuine Wilden parts if necessary.

## SECTION 8B – TURBO-FLO™ PUMPS

# AIR VALVE / CENTER SECTION REPAIR / MAINTENANCE

The air valve assembly consists of the air valve body and piston. The unique design of the air valve relies only on differential pressure to cause the air valve to shift. It is reliable and simple to maintain. The bushing in the center block, along with the diaphragm shaft, provides the “trigger” to tell the air valve to shift. The following procedure will ensure that the air valve on your Wilden pump will provide long trouble-free service.

### AIR VALVE BODY AND PISTON ASSEMBLY AND DISASSEMBLY

The air valve body and piston can be disconnected from the pump by removing the four socket-head cap screws which attach it to the center section. The piston in the air valve is aluminum with a dark anodized coating (see *Figure A*). The piston should move freely and the ports in the piston should line up with the ports on the face of the air valve body. The piston should also appear to be dull black in color. If the piston appears to be a shiny aluminum color, the air valve is probably worn beyond working tolerances and should be replaced.

If the piston does not move freely in the air valve, the entire air valve should be immersed in a cleaning solution. (NOTE: Do not force the piston by inserting a metal object.) This soaking should remove any accumulation of sludge and grit which is preventing the air valve piston from moving freely. If the air valve piston does not move freely after the above cleaning, the air valve should be disassembled as follows: Remove the snap ring from the top end of the air valve and apply an air jet alternately to the two holes located in the face of the air valve until the end cap is blown out. (See *Figure B*, next page) [CAUTION: The air valve end cap may come out with considerable force. Hand protection such as a padded glove or a rag should be used to capture the end cap.] Inspect the piston and cylinder bore for nicks and scoring.

Small nicks can usually be dressed out and the piston returned to service. Inspect the cylinder end caps. Make sure that the guide pin is straight and smooth or the piston will not move freely in the cylinder. Clean out anti-centering pin holes located on each side of the piston. Pin holes are located on each side of the annular groove on the top of the piston and travel to each end. New o-rings should be installed on the end caps. Lubricate the o-rings and install the end caps, assuring that proper alignment of the piston and cylinder ports is maintained. Use an oil with arctic characteristics (ISO 15-5wt).

### GLYD™ RING REPLACEMENT/ CENTER SECTION

The pump's center section consists of a molded housing with a bronze bushing. (Bushing is not removable.) This bushing has grooves cut into the inside diameter. Glyd™ rings are installed in these grooves. When the Glyd™ rings become worn, they will no longer seal and must be replaced.

There are two versions of center sections: PRE-ENHANCED (pumps manufactured before March 1, 1992) and ENHANCED (pumps manufactured since March 1, 1992). An encircled letter “E” stamped on the top of the center section denotes the ENHANCED type center section (*Figure C*).

**Please contact your local authorized distributor for enhanced air distribution retrofit packages.**

**If the encircled “E” is present**, an enhanced (02-3800-03-07) shaft should be utilized to maximize performance. The center section Glyd™ rings (02-3210-55-225) must be installed in the appropriate grooves as shown (1, 3, 6, 8).

**If the encircled “E” is not present**, a pre-enhanced shaft (02-3800-03 or 02-3820-03) must be utilized. An enhanced (non-dented) shaft will not function correctly. The center section o-rings (02-3200-52) must be installed in the appropriate grooves as shown (1, 3, 4, 6).

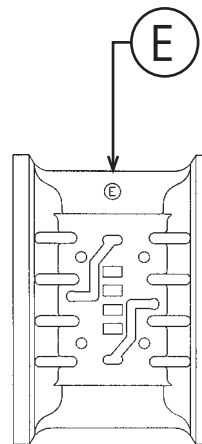
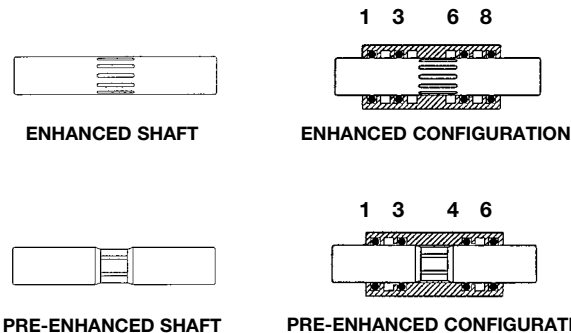

Figure C



## SECTION 8C

# REASSEMBLY HINTS & TIPS

### ASSEMBLY:

Upon performing applicable maintenance to the air distribution system, the pump can now be reassembled. Please refer to the disassembly instructions for photos and parts placement. To reassemble the pump, follow the disassembly instructions in reverse order. The air distribution system needs to be assembled first, then the diaphragms and finally the wetted path. Please find the applicable torque specifications on this page. The following tips will assist in the assembly process.

- Clean the inside of the center section shaft bushing to ensure no damage is done to new seals.
- Stainless bolts should be lubed to reduce the possibility of seizing during tightening.

### MAXIMUM TORQUE SPECIFICATIONS

Description of Part	Metal Pumps
Air Valve	3.4 N•m (30 in-lbs)
Outer Piston, Rubber and PTFE-Fitted	40.7 N•m (30 ft-lbs)
Vertical Bolts	13.0 N•m (115 in-lbs)

- Level the water chamber side of the intake/discharge manifold to ensure a proper sealing surface. This is most easily accomplished by placing them on a flat surface prior to tightening their clamp bands to the desired torque (see this page for torque specs).
- Be sure to tighten outer pistons simultaneously on PTFE-fitted pumps to ensure proper torque values.
- Place one liquid chamber on its side and align center section with chamber using alignment marks made during disassembly. Push down on diaphragm assembly until diaphragm is inverted. Place opposite liquid chamber on center section and align.
- Position valve balls, seats, and o-rings in discharge manifold. Place vertical through discharge manifold with threads pointing up. Install washer and start threads of bolt (about 1-1/2 turns).
- Place center section and liquid chambers on intake manifold.
- Position discharge manifold and bolt assembly on liquid chambers. Ensure proper alignment of mating surfaces between liquid chambers and manifolds before tightening bolts.
- Apply a small amount of Loctite 242 to the steel bore of the shaft from the diaphragm assembly.

## UL LISTED PUMPS

### ASSEMBLY:

Upon performing applicable maintenance to the air distribution system, the UL pump can now be reassembled. Please refer to the disassembly instructions for photos and parts placement. To reassemble the pump, follow the disassembly instructions in reverse order. The air distribution system needs to be assembled first, then the diaphragms and finally the wetted path. Please find the applicable torque specifications on this page. The following tips will assist in the assembly process.

- Clean the inside of the center section shaft bushing to ensure no damage is done to new seals.
- Stainless steel bolts should be lubed to reduce the possibility of seizing during tightening.
- Level the water chamber side of the intake/discharge manifold to ensure a proper sealing surface. This is most easily accomplished by placing them on a flat surface prior to tightening their vertical bolts to the desired torque.
- Apply a small amount of Loctite 242 to the steel bore of the shaft from the diaphragm assembly.
- Be sure to tighten outer pistons simultaneously on PTFE-fitted pumps to ensure proper torque values.

- Place one liquid chamber on its side and align center section with chamber using alignment marks made during disassembly. Push down on diaphragm assembly until diaphragm is inverted. Place opposite liquid chamber on center section and align.
- Position valve balls, seats, and o-rings in discharge manifold. Install vertical bolts through discharge manifold with threads pointing up. Install washer and start threads of bolt (about 11 turns).
- Place center section and liquid chambers on intake manifold.
- Position discharge manifold and bolt assembly on liquid chambers. Ensure proper alignment of mating surfaces between liquid chambers and manifolds before tightening vertical bolts.
- After vertical bolts are tightened, install two (#1 & #2) of the four jumper wires to the front-right vertical bolt. Install grounding tag. Install jam nut onto vertical bolt.
- Route #1 jumper wire to back of pump and attach to liquid chamber with 1/4-20 fastener.
- Route #2 jumper wire to the top of the center section.
- Install #3 jumper wire to the muffler plate using 1/4-20 fastener. Ensure the small eyelet of jumper wire is used at this location.
- Route #3 jumper wire from muffler plate to the top of the center section. Using one 1/4-20 fastener, install the #3 jumper wire, then install the #2 jumper wire over the top of the #3 jumper wire. The #2 jumper wire should have the small eyelet for use in this connection.
- Install #4 jumper wire to the front-left vertical bolt. Install jam nut onto vertical bolt.
- Route the #4 wire to front of pump (left liquid chamber) and attach to liquid chamber with 1/4-20 fastener.

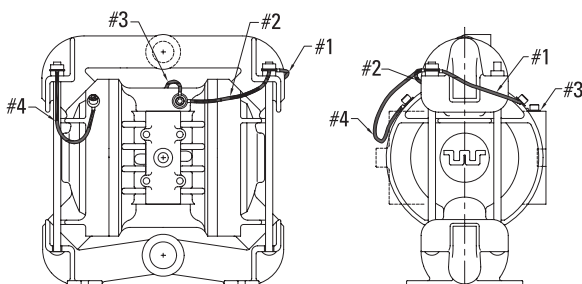



# Elastomer Kits

## *Your Solutions — Wrapped Up*

### ***Program Details:***

- **Elastomer & ADS Repair Kits**
- **All Sizes Available**
- **PTFE, Rubber & TPE Elastomers**
- **One Part Number Simplifies Inventory**
- **Eliminates Order Errors**
- **Reduces Re-Build Time**
- **Rejuvenates Your Pump**

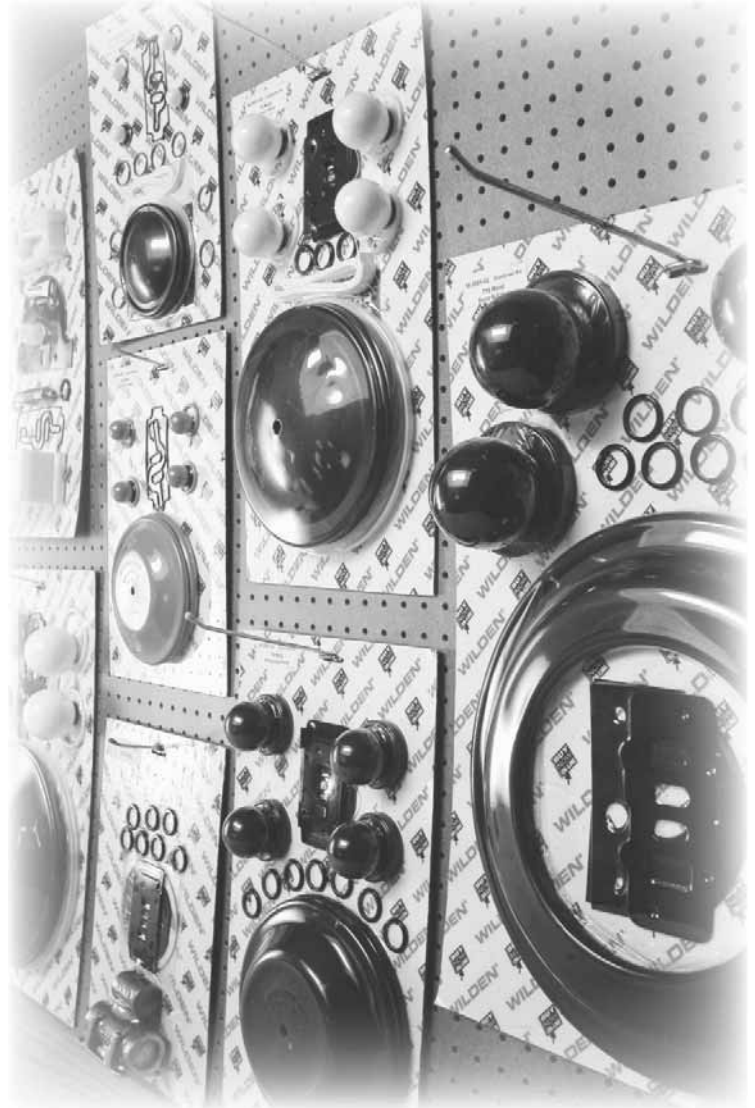

*NOTE: See Section 9.*

**WILDEN®**  
A DOVER COMPANY

22069 VAN BUREN STREET • GRAND TERRACE, CA 92313-5607  
(909) 422-1730 • FAX (909) 783-3440  
[www.wildenpump.com](http://www.wildenpump.com)

# SECTION 9A

# EXPLODED VIEW/PARTS LISTING

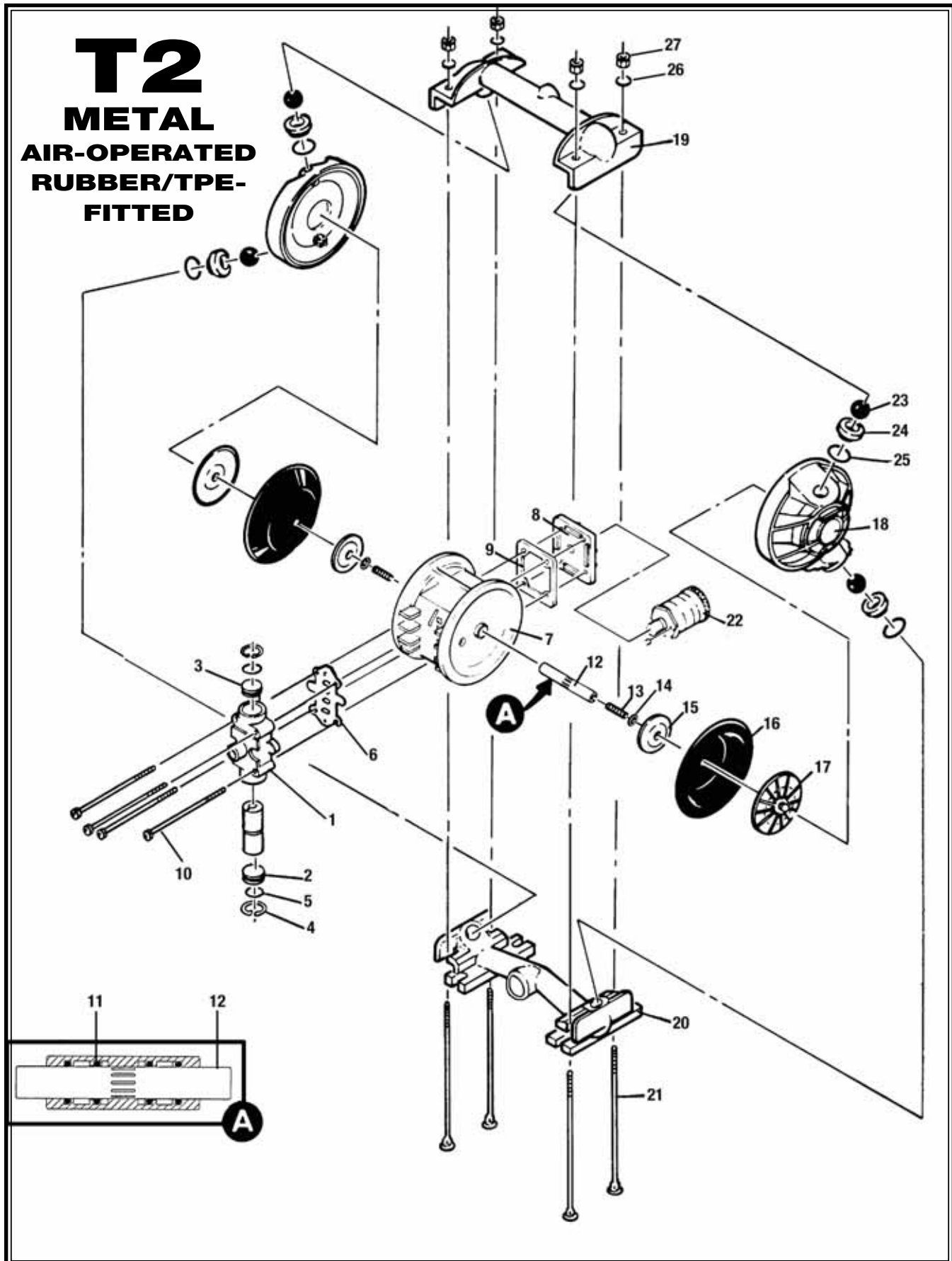

## T2 METAL Rubber/TPE-Fitted

Item	Description	Qty. Per Pump	T2/AAPPB	T2/SSPPB	T2/SSPPN/0070	T2/AAAAB	T2/SSAAB	T2/AAAAB/0090	T2/SSAAB/0090
			P/N	P/N	P/N	P/N	P/N	P/N	P/N
<b>1</b>	<b>Air Valve Assembly<sup>1</sup></b>	<b>1</b>	<b>02-2000-07</b>	<b>02-2000-07</b>	<b>02-2000-06</b>	<b>02-2000-07</b>	<b>02-2000-07</b>	<b>02-2000-07-390</b>	<b>02-2000-07-390</b>
2	Air Valve Cap w/Guide (Bottom)	1	02-2331-23	02-2331-23	02-2331-23	02-2331-23	02-2331-23	02-2330-01	02-2330-01
3	Air Valve Cap w/Guide (Top)	1	02-2301-23	02-2301-23	02-2301-23	02-2301-23	02-2301-23	02-2300-01	02-2300-01
4	Snap Ring	2	02-2650-03	02-2650-03	02-2650-03	02-2650-03	02-2650-03	02-2650-03	02-2650-03
5	Air Valve Cap O-Ring	2	02-3200-52-200	02-3200-52-200	02-3200-52-200	02-3200-52-200	02-3200-52-200	02-3200-52-200	02-3200-52-200
6	Air Valve Gasket — Buna-N	1	02-2600-52	02-2600-52	02-2600-52	02-2600-52	02-2600-52	02-2600-52	02-2600-52
7	Center Section <sup>1</sup>	1	02-3151-20-225	02-3151-20-225	02-3151-20-225	02-3150-01-225	02-3150-06-225	02-3150-01-90	02-3150-01-90
8	Muffler Plate	1	02-3180-20	02-3180-20	02-3180-20	02-3180-01	02-3180-01	02-3180-01-390	02-3180-01-390
9	Muffler Plate Gasket — Buna-N	1	02-3500-52-500	02-3500-52-500	02-3500-52-500	02-3500-52-110	02-3500-52-110	02-3500-52-110	02-3500-52-110
10	Air Valve Screws 1/4-20 x 6"	4	02-6000-08	02-6000-03	02-6000-03	02-6000-08	02-6000-03	02-6000-03	02-6000-03
	Hex Nut 1/4-20, ** (not shown)	4	04-6400-08	04-6400-03	04-6400-03	N/A	N/A	N/A	N/A
<b>11</b>	<b>Center Section Glyd™ Ring</b>	<b>4</b>	<b>02-3210-55-225</b>	<b>02-3210-55-225</b>	<b>02-3210-55-225</b>	<b>02-3210-55-225</b>	<b>02-3210-55-225</b>	<b>02-3210-55-225</b>	<b>02-3210-55-225</b>
12	Shaft	1	02-3800-03-07	02-3800-03-07	02-3800-03-07	02-3800-03-07	02-3800-03-07	02-3800-03-07	02-3800-03-07
13	Stud 3/8" -16 x -1/4"	2	N/R	02-6150-08	02-6150-08	N/R	02-6150-08	02-6150-08	02-6150-08
14	Disc Spring	2	02-6802-08	02-6802-08	02-6802-08	02-6802-08	02-6802-08	02-6802-08	02-6802-08
15	Pistons, Inner	2	02-3700-08	02-3700-08	02-3700-08	02-3700-08	02-3700-08	02-3700-08	02-3700-08
<b>16</b>	<b>Diaphragm*</b>	<b>2</b>	<b>*</b>	<b>*</b>	<b>02-1010-56</b>	<b>*</b>	<b>*</b>	<b>02-1010-52</b>	<b>02-1010-52</b>
17	Pistons, Outer	2	02-4550-01	02-4550-03	02-4550-03P	02-4550-01	02-4550-03	02-4550-01	02-4550-03
18	Liquid Chamber	2	02-5000-01	02-5000-03	02-5000-03P	02-5000-01	02-5000-03	02-5000-01-90	02-5000-03-90
19	Discharge Manifold	1	02-5020-01	02-5020-03	02-5025-03-70P	02-5020-01	02-5020-03	02-5020-01	02-5020-03
20	Inlet Housing	1	02-5080-01	02-5080-03	02-5085-03-70P	02-5080-01	02-5080-03	02-5080-01	02-5080-03
21	Manifold Bolt 3/6"-16 x 8-1/2"	4	02-6080-08	02-6080-03	02-6080-03	02-6080-08	02-6080-03	02-6080-03	02-6080-03
22	Muffler	1	02-3510-99	02-3510-99	02-3510-99	02-3510-99	02-3510-99	02-3510-99	02-3510-99
<b>23</b>	<b>Valve Balls*</b>	<b>4</b>	<b>*</b>	<b>*</b>	<b>02-1080-56</b>	<b>*</b>	<b>*</b>	<b>02-1080-52</b>	<b>02-1080-52</b>
<b>24</b>	<b>Valve Seat</b>	<b>4</b>	<b>02-1120-01</b>	<b>02-1120-03</b>	<b>02-1120-03P</b>	<b>02-1120-01</b>	<b>02-1120-03</b>	<b>02-1120-01</b>	<b>02-1120-03</b>
<b>25</b>	<b>Valve Seat O-Ring*</b>	<b>4</b>	<b>*</b>	<b>*</b>	<b>02-1200-56</b>	<b>*</b>	<b>*</b>	<b>02-1200-52-90</b>	<b>02-1200-52-90</b>
26	Manifold Bolt Washer 3/8"	4	15-6720-08	02-6730-03	08-6720-07-70	15-6720-08	02-6730-03	02-6730-03	02-6730-03
27	Manifold Bolt Nut 3/8"-16	4	02-6430-08	02-6430-03	02-6680-03-70	02-6430-08	02-6430-03	02-6430-03	02-6430-03
	Jumper Wire (not shown)	4	N/A	N/A	N/A	N/A	N/A	02-8301-99	02-8301-99
	Screw, SHC, 1/4-20 x 1/2" (not shown)	4	N/A	N/A	N/A	N/A	N/A	02-6033-03	02-6033-03
	Hex Nut, 3/8-16 (not shown)	2	N/A	N/A	N/A	N/A	N/A	02-6430-03	02-6430-03

<sup>1</sup>Air Valve Assembly includes items 2, 3, 4 and 5.

\*Refer to corresponding elastomer chart for metal pumps in Section 8.

\*\*Part to be used with item 10 to secure air valve and muffler plate.

NOTE: Models T2/SSPPN/0070 have 1-1/2" cast tri-clamp inlet and outlet ports and use wing nut type fasteners on manifold bolts.

**All boldface items are primary wear parts.**

# SECTION 9B

# EXPLODED VIEW/PARTS LISTING

**T2  
METAL  
AIR-OPERATED  
PTFE-  
FITTED**

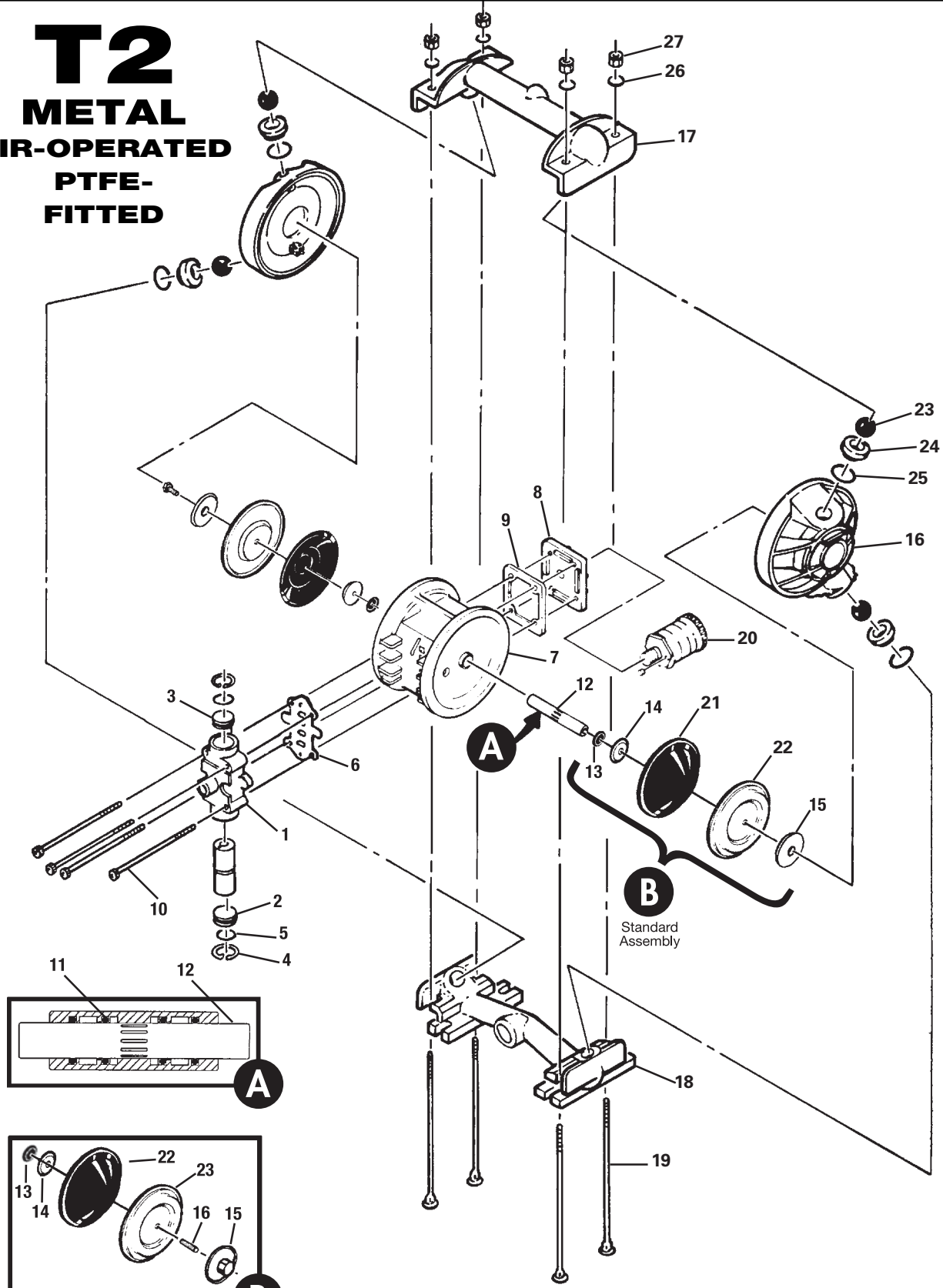

**STAINLESS STEEL PUMP  
DIAPHRAGM & PISTON ASSEMBLY**

## T2 METAL PTFE-Fitted

Item	Description	Qty. Per Pump	T2/AAPPB/ TNU/TF/ATF	T2/SSPPB/ TNU/TF/STF	T2/SSPPN/ TNU/TF/STF/0070	T2/AAAAB/ TNU/TF/ATF	T2/SSAAB/ TNU/TF/STF	T2/SSAAB/ TNU/TF/STF/0090
			P/N	P/N	P/N	P/N	P/N	P/N
<b>1</b>	<b>Air Valve Assembly<sup>1</sup></b>	<b>1</b>	<b>02-2000-07</b>	<b>02-2000-07</b>	<b>02-2000-06</b>	<b>02-2000-07</b>	<b>02-2000-07</b>	<b>02-2000-07-390</b>
2	Air Valve Cap wo/Guide (Bottom)	1	02-2331-23	02-2331-23	02-2331-23	02-2331-23	02-2331-23	02-2330-01
3	Air Valve Cap w/Guide (Top)	1	02-2301-23	02-2301-23	02-2301-23	02-2301-23	02-2301-23	02-2300-01
4	Snap Ring	2	02-2650-03	02-2650-03	02-2650-03	02-2650-03	02-2650-03	02-2650-03
5	Air Valve Cap O-Ring	2	02-3200-52-200	02-3200-52-200	02-3200-52-200	02-3200-52-200	02-3200-52-200	02-3200-52-200
6	Air Valve Gasket — Buna-N	1	02-2600-52	02-2600-52	02-2600-52	02-2600-52	02-2600-52	02-2600-52
7	Center Section	1	02-3151-20-225	02-3151-20-225	02-3151-20-225	02-3150-01-225	02-3150-01-225	02-3150-01-90
8	Muffler Plate	1	02-3180-20	02-3180-20	02-3180-20	02-3180-01	02-3180-01	02-3180-01-390
9	Muffler Plate Gasket — Buna-N	1	02-3500-52-500	02-3500-52-500	02-3500-52-500	02-3500-52-110	02-3500-52-110	02-3500-52-110
10	Air Valve Screws	4	02-6000-08	02-6000-03	02-6000-03	02-6000-08	02-6000-03	02-6000-03
	Hex Nut 1/4-20, ** (Not shown)	4	04-6400-08	04-6400-03	04-6400-03	N/A	N/A	N/A
11	Center Section Glyd™ Ring	4	02-3210-55-225	02-3210-55-225	02-3210-55-225	02-3210-55-225	02-3210-55-225	02-3210-55-225
<b>12</b>	<b>Shaft</b>	<b>1</b>	<b>02-3820-03-07</b>	<b>02-3820-03-07</b>	<b>02-3820-03-07</b>	<b>02-3820-03-07</b>	<b>02-3820-03-07</b>	<b>02-3820-03-07</b>
13	Disc Spring	2	02-6802-08	02-6802-08	02-6802-08	02-6802-08	02-6802-08	02-6802-08
14	Pistons — Inner	2	02-3750-01	02-3750-01	02-3750-01	02-3750-01	02-3750-01	02-3750-01
15	Pistons — Outer	2	02-4601-01	02-4600-03	02-4600-03P	02-4601-01	02-4600-03	02-4600-03
16	Stud	2	N/A	02-6150-08	02-6150-08	N/A	02-6150-08	02-6150-08
<b>17</b>	<b>Liquid Chamber</b>	<b>2</b>	<b>02-5000-01</b>	<b>02-5000-03</b>	<b>02-5000-03P</b>	<b>02-5000-01</b>	<b>02-5000-03</b>	<b>02-5000-03-90</b>
18	Discharge Manifold	1	02-5020-01	02-5020-03	02-5025-03-70P	02-5020-01	02-5020-03	02-5020-03
19	Inlet Housing	1	02-5080-01	02-5080-03	02-5085-03-70P	02-5080-01	02-5080-03	02-5080-03
20	Manifold Bolt 3/8"-16 x 8 1/2"	4	02-6080-08	02-6080-03	02-6080-03	02-6080-08	02-6080-03	02-6080-03
21	Muffler	1	02-3510-99	02-3510-99	02-3510-99	02-3510-99	02-3510-99	02-3510-99
22	Back-up Diaphragm*	2	02-1060-51	02-1060-51	02-1060-51	02-1060-51	02-1060-51	02-1060-51
23	Diaphragm	2	02-1010-55	02-1010-55	02-1010-55	02-1010-55	02-1010-55	02-1010-55
<b>24</b>	<b>Valve Balls</b>	<b>4</b>	<b>02-1080-55</b>	<b>02-1080-55</b>	<b>02-1080-55</b>	<b>02-1080-55</b>	<b>02-1080-55</b>	<b>02-1080-55</b>
<b>25</b>	<b>Valve Seat</b>	<b>4</b>	<b>02-1120-01</b>	<b>02-1120-03</b>	<b>02-1120-03P</b>	<b>02-1120-01</b>	<b>02-1120-03</b>	<b>02-1120-03</b>
<b>26</b>	<b>Valve Seat O-Ring</b>	<b>4</b>	<b>02-1200-55</b>	<b>02-1200-55</b>	<b>02-1200-55</b>	<b>02-1200-55</b>	<b>02-1200-55</b>	<b>02-1200-55</b>
27	Manifold Bolt Washer 3/8"	4	02-6720-08	02-6730-03	08-6720-07-70	15-6720-08	02-6730-03	02-6730-03
28	Manifold Bolt Nut 3/8"-16	4	02-6430-08	02-6430-03	02-6680-03-70	02-6430-08	02-6430-03	02-6430-03
	Jumper Wire (not shown)	4	N/A	N/A	N/A	N/A	N/A	02-8301-99
	Screw, SHC, 1/4-20 x 1/2" (not shown)	4	N/A	N/A	N/A	N/A	N/A	02-6033-03
	Hex Nut, 3/8-16 (not shown)	2	N/A	N/A	N/A	N/A	N/A	02-6430-03

<sup>1</sup>Air Valve Assembly includes items 2, 3, 4 and 5.

\*Required only for PTFE-fitted pumps. Saniflex™ back-up diaphragms, (P/N 02-1060-56) and EPDM back-up diaphragm, (P/N 02-1060-54) available upon request. Please consult your local distributor.

\*\*Part to be used with item 10 to secure air valve and muffler plate.

NOTE: Model T2/SSPPN/0070 has 1-1/2" cast tri-clamp inlet and outlet ports and uses wing nut type fasteners on manifold bolts.

0070 Specialty Code = Saniflo FDA

0090 Specialty Code = UL Listed

**All boldface items are primary wear parts.**

## SECTION 10A

# ELASTOMER OPTIONS

---

### T2 METAL

<b>Material</b>	<b>Diaphragm P/N</b>	<b>Valve Ball P/N</b>	<b>Valve Seat P/N</b>	<b>Valve Seat O-Ring* P/N</b>
Polyurethane	02-1010-50	02-1080-50	N/A	02-1200-50
Buna-N	02-1010-52	02-1080-52	N/A	02-1200-52
Neoprene	02-1010-51	02-1080-51	N/A	N/A
EPDM	02-1010-54	02-1080-54	N/A	02-1200-54
Viton®	02-1010-53	02-1080-53	N/A	N/A
Wil-Flex™	02-1010-58	02-1080-58	N/A	02-1200-58
Saniflex™	02-1010-56	02-1080-56	N/A	02-1200-56
PTFE	02-1010-55	02-1080-55	N/A	02-1200-55
Stainless Steel	N/A	N/A	02-1120-03	N/A
Aluminum	N/A	N/A	02-1120-01	N/A

**WARRANTY**

Each and every product manufactured by Wilden Pump and Engineering, LLC is built to meet the highest standards of quality. Every pump is functionally tested to insure integrity of operation.

Wilden Pump and Engineering, LLC warrants that pumps, accessories and parts manufactured or supplied by it to be free from defects in material and workmanship for a period of five (5) years from date of installation or six (6) years from date of manufacture, whichever comes first. Failure due to normal wear, misapplication, or abuse is, of course, excluded from this warranty.

Since the use of Wilden pumps and parts is beyond our control, we cannot guarantee the suitability of any pump or part for a particular application and Wilden Pump and Engineering, LLC shall not be liable for any consequential damage or expense arising from the use or misuse of its products on any application. Responsibility is limited solely to replacement or repair of defective Wilden pumps and parts.

All decisions as to the cause of failure are the sole determination of Wilden Pump and Engineering, LLC.

Prior approval must be obtained from Wilden for return of any items for warranty consideration and must be accompanied by the appropriate MSDS for the product(s) involved. A Return Goods Tag, obtained from an authorized Wilden distributor, must be included with the items which must be shipped freight prepaid.

The foregoing warranty is exclusive and in lieu of all other warranties expressed or implied (whether written or oral) including all implied warranties of merchantability and fitness for any particular purpose. No distributor or other person is authorized to assume any liability or obligation for Wilden Pump and Engineering, LLC other than expressly provided herein.

**PLEASE PRINT OR TYPE AND FAX TO WILDEN**

PUMP INFORMATION			
Item # _____		Serial # _____	
Company Where Purchased _____			
YOUR INFORMATION			
Company Name _____			
Industry _____			
Name _____		Title _____	
Street Address _____			
City _____		State _____	Postal Code _____
Country _____			
Telephone _____		Fax _____	Web Address _____
E-mail _____			
Number of pumps in facility? _____		Number of Wilden pumps? _____	
Types of pumps in facility (check all that apply): <input type="checkbox"/> Diaphragm <input type="checkbox"/> Centrifugal <input type="checkbox"/> Gear <input type="checkbox"/> Submersible <input type="checkbox"/> Lobe			
<input type="checkbox"/> Other _____			
Media being pumped? _____			
How did you hear of Wilden Pump? <input type="checkbox"/> Trade Journal <input type="checkbox"/> Trade Show <input type="checkbox"/> Internet/E-mail <input type="checkbox"/> Distributor			
<input type="checkbox"/> Other _____			

**ONCE COMPLETE, FAX TO (909) 783-3440**

NOTE: WARRANTY VOID IF PAGE IS NOT FAXED TO WILDEN

WILDEN PUMP & ENGINEERING, LLC